

# Hydraulic cylinders

## Mill type

**RE 17338/07.17**  
Replaces: 01.16

1/74

### Series CDH3 / CGH3 / CSH3

Component series 3X  
Nominal pressure 350 bar (35 MPa)

HA/4646/95



## Table of contents

### Contents

Features	1	Pin assignment for Profibus	49
Technical data	2, 3	Plain clevis CSA	50
Project planning software ICS	3	Swivel head CGA	51
Diameters, areas, forces, flow	4	Swivel head CGAK	52, 53
Tolerances according to ISO 6020-1	4	Swivel head CGAS	54, 55
Overview types of mounting: Series CDH3 and CGH3	5	Kinking	56
Ordering code series CDH3 and CGH3	6 ... 9	Admissible stroke length	56 ... 58
Types of mounting and dimensions CDH3 and CGH3	10 ... 21	End position cushioning	59 ... 61
Ordering code, overview of types of mounting CSH3	22, 23	Selection criteria for seals	62
Types of mounting and dimensions CSH3	24 ... 35	Seal kits	63.. 67
Flange ports	36, 37	Tightening torques	68
Subplates for valve mounting	38 ... 41	Spare parts: Series CDH3	69
Bleeding / measuring coupling	42	Spare parts: Series CGH3	70
Throttle valve	42	Spare parts: Series CSH3 MP3 and MP5	71
Proximity switch	43 ... 45	Spare parts: Series CSH3 MF3, MF4, MT4 and MS2	72
Position measurement system	46 ... 48	Cylinder weight	73
		Corrosivity categories	74

### Features

- 6 types of mounting
- Piston Ø (**ØAL**): 40 to 320 mm
- Piston rod Ø (**ØMM**): 28 to 220 mm
- Stroke lengths up to 6 m
- Self-adjusting and adjustable end position cushioning

Project planning software Interactive **Catalog System****Online**[www.boschrexroth.com/ics](http://www.boschrexroth.com/ics)

## Technical data (For applications outside these parameters, please consult us.)

### Standards:

Bosch Rexroth standard; main dimensions like piston  $\varnothing$  and piston rod  $\varnothing$  correspond to ISO 3320.

**Nominal pressure:** 350 bar

Static test pressure: 525 bar

Reduced test pressure: 315 bar

The maximum operating pressures must be less than or equal to the applicable nominal pressures and apply to applications with shock-free operation with reference to excess pressure and/or external loads. With extreme loads like e.g. high sequence cycle, mounting elements and threaded piston rod connections must be designed for durability.

### Minimum pressure:

Depending on the application, application conditions and technical design, a certain minimum pressure (approx. 10 bar) is required in order to guarantee technically unobjectionable functioning of the hydraulic cylinder.

**Installation position:** any

### Hydraulic fluid (amending data sheet):

Mineral oils DIN 51524 HL, HLP (90220)

Oil-in-water emulsion HFA (90223)

Water glycol HFC (90223)

Phosphate ester HFDR (90222)

Polyol ester HFDU (90222)

**Hydraulic fluid temperature range:** see page 62

**Ambient temperature range:** see page 62

**Optimum viscosity range:** 20 to 100 mm<sup>2</sup>/s

**Minimum admissible viscosity:** 12 mm<sup>2</sup>/s

**Maximum admissible viscosity:** 380 mm<sup>2</sup>/s

### Cleanliness class acc. to ISO

Maximum admissible degree of contamination of the hydraulic fluid according to ISO 4406 (c) class 20/18/15.

The cleanliness classes specified for the components must be adhered to in hydraulic systems. Effective filtration prevents faults and simultaneously increases the life cycle of the components.

For the selection of the filters see [www.boschrexroth.com/filter](http://www.boschrexroth.com/filter)

**Bleeding:** by default secured against screwing out

### Color set-up:

**Priming:** By default, hydraulic cylinders are primed with a coating (color gentian blue RAL 5010) of min. 40  $\mu$ m, see page 74.

Other colors upon request.

With cylinders and attachment parts, the following surfaces are not primed:

- All fit diameters to the customer side
- Sealing surfaces for line connection
- Sealing surfaces for flange connection
- Connection surface for valve mounting
- Inductive proximity switches

- Position measurement system
- Measuring coupling
- Spherical / plain bearing
- Lubricating nipples

**Painting:** By default, hydraulic cylinders can be ordered in four corrosivity categories in the RAL colors, see page 74. With cylinders and attachment parts, the following surfaces are not painted:

- All fit diameters and connection surfaces to the customer side
- Sealing surfaces for line connection
- Sealing surfaces for flange connection
- Connection surface for valve mounting
- Inductive proximity switches
- Position measurement system
- Measuring coupling
- Spherical / plain bearing
- Lubricating nipples

The areas that are not primed or painted are protected by means of a solvent-free corrosion protection agent.

Accessories that are ordered as separate order item are not primed or painted by default. Corresponding priming and/or painting on request.

**Stroke velocity:** Please observe the guideline on max. stroke velocities (with recommended flow velocity of 5 m/s in the line connection) in the table. Higher stroke velocity upon request. If the extension velocity is considerably higher than the retraction velocity of the piston rod, drag-out losses of the medium may result. If necessary, please consult us.

Piston $\varnothing$ (mm)	Line connection	max. stroke velocity in m/s
40	G1/2	0.31
50	G1/2	0.20
63	G3/4	0.28
80	G3/4	0.18
100	G1	0.20
125	G1 1/4	0.20
140	G1 1/4	0.16
160	G1 1/2	0.18
180	G1 1/2	0.14
200	G1 1/2	0.11
220	G1 1/2	0.09
250	G1 1/2	0.07
280	G1 1/2	0.06
320	G1 1/2	0.04

## Technical data (For applications outside these parameters, please consult us.)

---

### Boundary and application conditions:

- The mechanical alignment of the movement axis and thus the mounting points of hydraulic cylinder and piston rod must be ensured. Lateral forces on the guides of piston rod and piston are to be avoided. It may be necessary to consider the own weight of the hydraulic cylinder (MP3/MP5 or MT4) or the piston rod.
- The bending length/bending load of the piston rod and/or the hydraulic cylinder must be observed (see page topic Kinking).
- The maximum admissible stroke velocities with regard to the suitability/load of seals must be observed as must their compatibility with the properties of the hydraulic fluid (see page topic Seals).
- The maximum admissible velocities/kinetic energies when moving into the end positions, also considering external loads, must be observed.  
Danger: Excess pressure
- The maximum admissible operating pressure must be complied with in any operating state of the hydraulic cylinder. Possible pressure intensification resulting from the area ratio of annulus area to piston area and possible throttling points are to be observed.
- Detrimental environmental influences, like e.g. aggressive finest particles, vapors, high temperatures, etc. as well as contamination and deterioration of the hydraulic fluid are to be avoided.

### Notice:

- This list does not claim to be complete. In case of questions regarding the compatibility with the medium or exceedance of the boundary or application conditions, please contact us.
- All graphical representations in the data sheet are examples. The product supplied may therefore differ from the figure shown.

### Acceptance:

Each cylinder is tested according to Bosch Rexroth standard and in compliance with ISO 10100: 2001.

### Safety instructions:

For assembly, commissioning and maintenance of hydraulic cylinders, observe the operating instructions 07100-B! Service and repair work has to be performed by Bosch Rexroth AG or by personnel especially trained for this purpose. No warranty is accepted for damage as a consequence of assembly, maintenance or repair work not performed by Bosch Rexroth AG.

### Check lists for hydraulic cylinders:

Cylinders the characteristics and/or application parameters of which deviate from the values specified in the data sheet can only be offered as a special version upon request. For offers, the deviations of the characteristics and/or application parameters must be described in the check lists for hydraulic cylinders (07200).

### Minimum strokes:

When using end position cushioning, the minimum stroke must also be observed, see page 59 "End position cushioning".

## Project planning software ICS (Interactive Catalog System)

---

The ICS (Interactive Catalog System) is a selection and Project planning aid for hydraulic cylinders. The ICS allows designers for machines and systems to quickly and reliably find the perfect hydraulic cylinder solution through logic-guided type key enquiries. This software helps to solve design and project planning tasks more quickly and efficiently. After having been guided through the product selection, the

user quickly and reliably gets the exact technical data of the selected component as well as 2D and 3D CAD data in the correct file format for all common CAD systems.

This allows users to reduce costs while increasing their competitiveness.

[www.boschrexroth.com/ics](http://www.boschrexroth.com/ics)

## Diameters, areas, forces, flow

Piston $\varnothing AL$ mm	Piston rod $\varnothing MM$ mm	Area ratio $\varphi$ $A_1/A_3$	Areas			Force at 350 bar <sup>1)</sup>			Flow at 0.1 m/s <sup>2)</sup>			max. available stroke length mm
			Piston $A_1$ cm <sup>2</sup>	Rod $A_2$ cm <sup>2</sup>	Ring $A_3$ cm <sup>2</sup>	Pressure $F_1$ kN	Diff. $F_2$ kN	Pulling $F_3$ kN	Off $q_{V1}$ l/min	Diff. $q_{V2}$ l/min	On $q_{V3}$ l/min	
40	28	1.96	12.56	6.16	6.40	43.96	21.56	22.40	7.5	3.7	3.8	2000
50	36	2.08	19.63	10.18	9.45	68.71	35.63	33.08	11.8	6.1	5.7	2000
63	45	2.04	31.17	15.90	15.27	109.10	55.65	53.45	18.7	9.5	9.2	2000
80	56	1.96	50.26	24.63	25.63	175.91	86.21	89.71	30.2	14.8	15.4	2000
100	70	1.96	78.54	38.48	40.06	274.89	134.68	140.21	47.1	23.1	24.0	3000
125	90	2.08	122.72	63.62	59.10	429.52	222.67	206.85	73.6	38.2	35.4	3000
140	100	2.04	153.94	78.54	75.40	538.79	274.89	263.90	92.4	47.1	45.3	3000
160	110	1.90	201.06	95.06	106.00	703.71	332.71	371.00	120.6	57.0	63.6	3000
180	125	1.93	254.47	122.72	131.75	890.65	429.52	461.13	152.7	73.6	79.1	3000
200	140	1.96	314.16	153.96	160.20	1099.56	538.86	560.70	188.5	92.4	96.1	3000
220	160	2.12	380.1	201.0	179.1	1330.5	703.7	626.8	228.1	120.7	107.4	6000
250	180	2.08	490.8	254.4	236.4	1718.1	890.6	827.4	294.5	152.7	141.8	6000
280	200	2.04	615.7	314.1	301.6	2155.1	1099.6	1055.6	369.4	188.5	180.9	6000
320	220	1.90	804.2	380.1	424.2	2814.9	1330.5	1484.4	482.5	228.1	254.4	6000

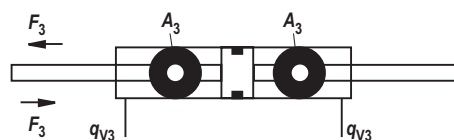
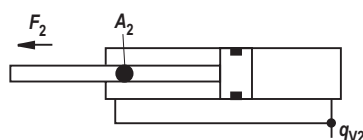
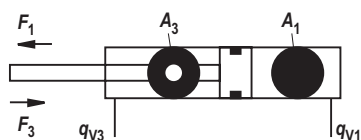

<sup>1)</sup> Theoretical, static cylinder force  
(without consideration of the efficiency and admissible load  
for attachment parts like e. g. swivel heads, plates or  
valves, etc.)

<sup>2)</sup> Stroke velocity

## Tolerances according to DIN ISO 6022

Installation dimensions	WC	XC <sup>2)</sup>	XO <sup>2)</sup>	XS <sup>1), 2)</sup>	XV <sup>2)</sup>	ZP <sup>2)</sup>	Stroke tolerances <sup>3)</sup>
Type of mounting	MF3	MP3	MP5	MS2	MT4	MF4	
Stroke length	Tolerances						
≤ 1250	±2	±1.5	±1.5	±2	±2	±1.5	+2
> 1250 – ≤ 3150	±4	±3	±3	±4	±4	±3	+5
> 3150 – ≤ 6000	±8	±5	±5	±8	±8	±5	+8

<sup>1)</sup> Not standardized

<sup>2)</sup> Including stroke length

<sup>3)</sup> Stroke tolerances must not be added to the tolerances listed in this table.

## Overview types of mounting: Series CDH3 and CGH3

---

### CDH3 MP3

see page 10, 11



### CDH3 MP5

see page 12, 13



### CDH3 MF3

see page 14, 15

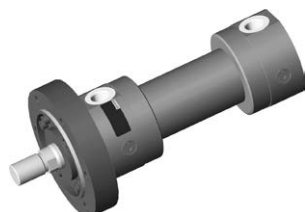

### CGH3 MF3

see page 14, 15

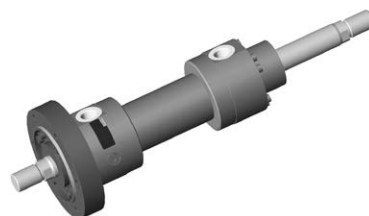

### CDH3 MF4

see page 16, 17



### CDH3 MT4

see page 18, 19



### CGH3 MT4

see page 18, 19



### CDH3 MS2

see page 20, 21



### CGH3 MS2

see page 20, 21

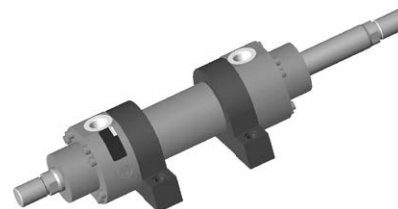

## Ordering code series CDH3

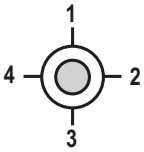
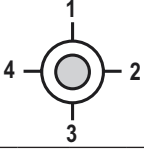
CD		H3		/	/	/	A	3X	/	/	/	/	/	/	/	/	/	/	/	/
<b>Differential cylinder</b>		<b>Option</b>																		
= CD		W = Without additional options, do <b>not</b> fill fields for additional options																		
<b>Series</b>		Z = Additional options, fill fields for additional options																		
= H3		<b>Seal design</b>																		
<b>Types of mounting</b>		<b>For mineral oil HL, HLP and HFA</b>																		
Swivel eye at base <sup>1)</sup> = MP3		M = Standard seal system																		
Self-aligning clevis at base = MP5		L = Standard seal system with guide rings																		
Round flange at head = MF3		R = Reduced friction heavy industry																		
Round flange at base = MF4		<b>For mineral oil HL, HLP, HFA and water glycol HFC</b>																		
Trunnion <sup>2)</sup> = MT4		G = <sup>27)</sup> Standard seal system HFC																		
Foot mounting = MS2		T = Servo quality/reduced friction																		
<b>Piston Ø (ØAL) 40 to 320 mm</b>		A = Chevron seal kits																		
<b>Piston rod Ø (ØMM) 28 to 220 mm</b>		<b>For phosphate ester HFD-R and polyol ester HFD-U</b>																		
<b>Stroke length in mm <sup>3)</sup></b>		S = Servo quality/reduced friction																		
<b>Design principle</b>		V = <sup>27)</sup> Standard seal system FKM																		
Head and base flanged = A		B = Chevron seal kits																		
<b>Component series</b>		<b>End position cushioning</b>																		
30 to 39 unchanged installation and connection dimensions = 3X		U = Without																		
<b>Line connection / version</b>		D = <sup>1)</sup> On both sides, self-adjusting																		
according to ISO 1179-1 (pipe thread ISO 228-1) = B		E = On both sides, adjustable																		
according to ISO 9974-1 (metric thread ISO 261) = M		<b>Piston rod end</b>																		
Flange porting pattern according to ISO 6162-2 tab. 2 type 1 (≙ SAE 6000 PSI) <sup>4) 25)</sup> = D		A = Thread for swivel head CGAS																		
Flange porting pattern according to ISO 6164 tab. 2 <sup>4)</sup> = H		G = <sup>26)</sup> Thread for swivel head CGA, CGAK, plain clevis CSA																		
according to ISO 1179-1 (pipe thread ISO 228-1) with flat pipe flange <sup>31)</sup> = C		S = With mounted swivel head CGAS																		
<b>for directional and high-response valves</b>		L = <sup>26)</sup> With mounted swivel head CGA																		
Subplate NG6 <sup>4) 5) 27)</sup> = P		M = <sup>26)</sup> With mounted swivel head CGAK																		
Subplate NG10 <sup>4) 6) 27)</sup> = T		N = <sup>1)</sup> With mounted plain clevis CSA																		
Subplate NG16 <sup>4) 7) 27)</sup> = U																				
Subplate NG25 <sup>4) 8) 27)</sup> = V																				
<b>for SL and SV valves</b>																				
Subplate NG6 <sup>4) 5) 15) 27)</sup> = A																				
Subplate NG10 <sup>4) 6) 15) 27)</sup> = E																				
Subplate NG20 <sup>4) 7) 15) 27)</sup> = L																				
Subplate NG30 <sup>4) 8) 15) 27)</sup> = N																				
<b>Line connection/position at head</b>																				
View to piston rod																				
		<sup>30)</sup> = 1 <sup>30)</sup> = 2 <sup>30)</sup> = 3 <sup>30)</sup> = 4																		
<b>Line connection/position at base</b>																				
View to piston rod																				
		<sup>30)</sup> = 1 <sup>30) 34)</sup> = 2 <sup>30)</sup> = 3 <sup>30) 34)</sup> = 4																		
<b>Piston rod design</b>																				
Hard chromium-plated = C																				
Hardened and hard chromium-plated <sup>24)</sup> = H																				
Nickel-plated and hard chromium-plated <sup>19)</sup> = N																				





### Ordering code series CGH3

CG	H3	/	/	/	A	3X	/												
----	----	---	---	---	---	----	---	--	--	--	--	--	--	--	--	--	--	--	--

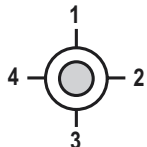
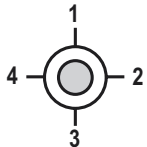
<b>Double-acting cylinder</b> <sup>18)</sup> = CG	
<b>Series</b> = H3	
<b>Types of mounting</b>	
Round flange at head = MF3	
Trunnion <sup>2)</sup> = MT4	
Foot mounting = MS2	
<b>Piston Ø (ØAL) 40 to 320 mm</b>	
<b>Piston rod Ø (ØMM) 28 to 220 mm</b>	
<b>Stroke length in mm</b> <sup>3)</sup>	
<b>Design principle</b>	
Head and base flanged = A	
<b>Component series</b>	
30 to 39 unchanged installation and connection dimensions = 3X	
<b>Line connection / version</b>	
according to ISO 1179-1 (pipe thread ISO 228-1) = B	
according to ISO 9974-1 (metric thread ISO 261) = M	
Flange porting pattern according to ISO 6162-2 tab. 2 type 1 (SAE 6000 PSI) <sup>25)</sup> = D	
Flange porting pattern according to ISO 6164 tab. 2 = H	
according to ISO 1179-1 (pipe thread ISO 228-1) with flat pipe flange <sup>31)</sup> = C	
<b>Line connection/position at head</b>	
View to piston rod	 <sup>30)</sup> = 1 <sup>30)</sup> = 2 <sup>30)</sup> = 3 <sup>30)</sup> = 4
<b>Line connection/position at base</b>	
View to piston rod	 <sup>30)</sup> = 1 <sup>30)</sup> = 2 <sup>30)</sup> = 3 <sup>30)</sup> = 4
<b>Piston rod design</b>	
Hard chromium-plated = C	
Hardened and hard chromium-plated <sup>24)</sup> = H	

<b>Option</b>
<b>W</b> = Without additional options, do <b>not</b> fill fields for additional options
<b>Z</b> = Additional options, fill fields for additional options
<b>Seal design</b>
<b>For mineral oil HL, HLP and HFA</b>
<b>M</b> = Standard seal system
<b>L</b> = Standard seal system with guide rings
<b>R</b> = Reduced friction heavy industry
<b>For mineral oil HL, HLP, HFA and water glycol HFC</b>
<b>G</b> = <sup>27)</sup> Standard seal system HFC
<b>T</b> = Servo quality/reduced friction
<b>A</b> = Chevron seal kits
<b>For phosphate ester HFD-R and polyol ester HFD-U</b>
<b>S</b> = Servo quality/ reduced friction
<b>V</b> = <sup>27)</sup> Standard seal system FKM
<b>B</b> = Chevron seal kits
<b>End position cushioning</b>
<b>U</b> = Without
<b>D</b> = <sup>1)</sup> On both sides, self-adjusting
<b>E</b> = On both sides, adjustable
<b>Piston rod end</b>
<b>A</b> = Thread for swivel head CGAS
<b>G</b> = <sup>26)</sup> Thread for swivel head CGA, CGAK, plain clevis CSA
<b>S</b> = <sup>26)</sup> <sup>17)</sup> With mounted swivel head CGAS
<b>L</b> = <sup>26)</sup> <sup>17)</sup> With mounted swivel head CGA
<b>M</b> = <sup>26)</sup> <sup>17)</sup> With mounted swivel head CGAK
<b>N</b> = <sup>1)</sup> <sup>17)</sup> With mounted plain clevis CSA



## Ordering code series CGH3

### Additional options

Fields for additional options

Z																				
---	--	--	--	--	--	--	--	--	--	--	--	--	--	--	--	--	--	--	--	--

Without inductive proximity switches

= W

Inductive proximity switches

<sup>37)</sup> = E

**without** mating connector

Mating connector, separate order, see page 44

Without additional guide rings

= W

Additional guide rings

<sup>10), 28)</sup> = F

Without measuring coupling

= W

Measuring coupling, on both sides

= A

Standard conical grease nipples, DIN 71412 form A

= W

Spherical bearing, maintenance-free

<sup>14)</sup> = A

Flanged grease nipples, DIN 3404 form A

= B

W = without test certificate  
C = with acceptance test certificate 3.1 based on EN 10204

W = without oil filling  
F = with oil filling

W = Priming class CP3  
B = <sup>21)</sup> Painting class CP4  
L = <sup>21)</sup> Painting class CP5  
U = <sup>21)</sup> Painting class CP6  
E = <sup>21)</sup> Painting class CP7

W = without piston rod extension  
Y = <sup>16)</sup> Specify the piston rod extension LY in the plain text in mm

### Order examples:

Without additional options:

**CGH3MF3/100/56/300A3X/B11CADMW**

With additional options:

**CGH3MF3/100/56/300A3X/B11CADMZ EWABW WWW**

<sup>1)</sup> Only piston Ø 40 to 200 mm

<sup>2)</sup> Trunnion position freely selectable. When ordering, always specify the "XV" dimensions in the plain text in mm

<sup>3)</sup> Observe the max. stroke length available, page 4, and the admissible stroke length (according to kinking calculation) on pages 56 to 58

<sup>10)</sup> Seal designs A, B not possible;  
Piston Ø 220 to 320 mm standard

<sup>14)</sup> Not possible with plain clevis "N"

<sup>16)</sup> Only at left piston rod side (orientation: catalog figures)

<sup>17)</sup> Only one swivel head / plain clevis mounted, left piston rod side (orientation: catalog figures)

<sup>18)</sup> Not standardized

<sup>21)</sup> Specify RAL color in the plain text

<sup>24)</sup> Only piston rod Ø 28 to 140 mm

<sup>25)</sup> Only piston Ø 63 to 320 mm

<sup>26)</sup> Only piston Ø 40 to 250 mm

<sup>27)</sup> Maximum operating pressure 315 bar

<sup>28)</sup> With seal design "L" standard

<sup>30)</sup> All graphical representations in the data sheet show position 1

<sup>31)</sup> With MS2, only position 11 is possible

<sup>37)</sup> Min. stroke length = 20 mm

### Swivel eye at base CDH3: MP3

CDH3 MP3; 40 to 200 mm

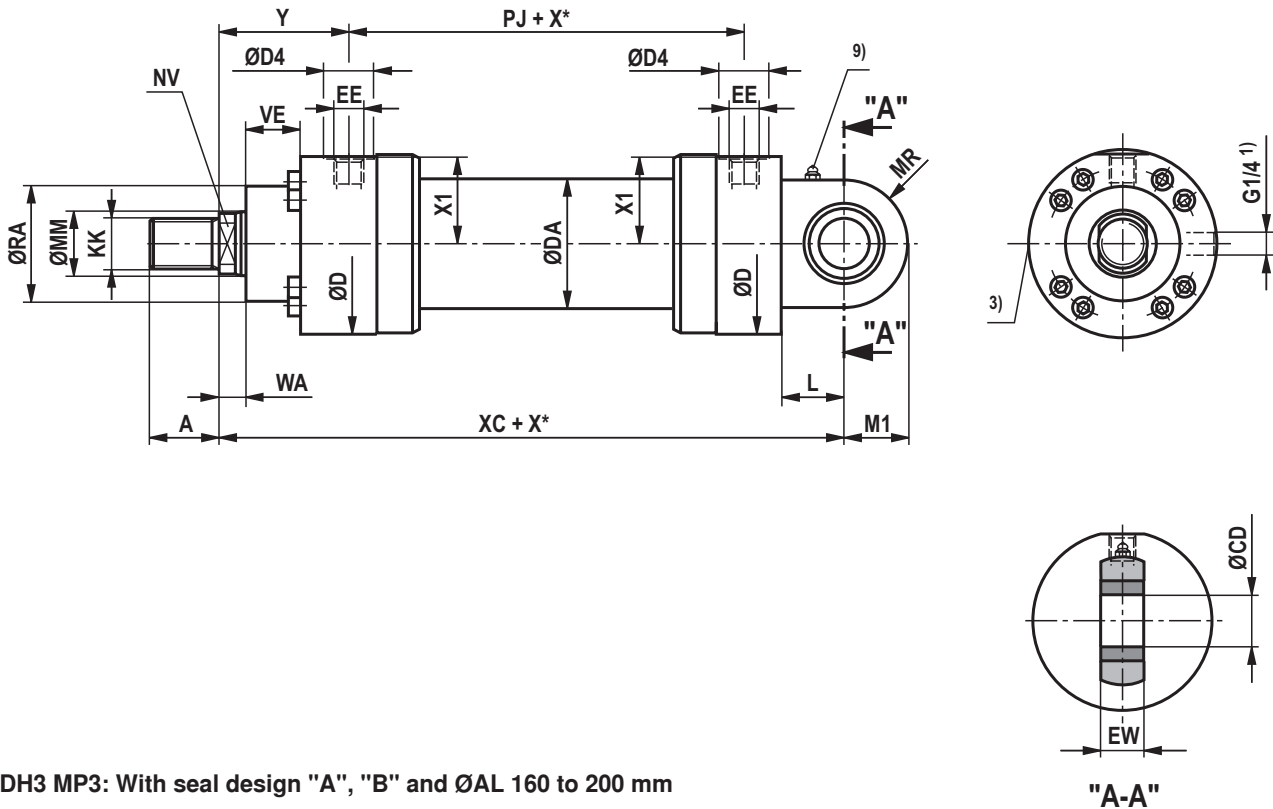

CDH3 MP3: With seal design "A", "B" and ØAL 160 to 200 mm

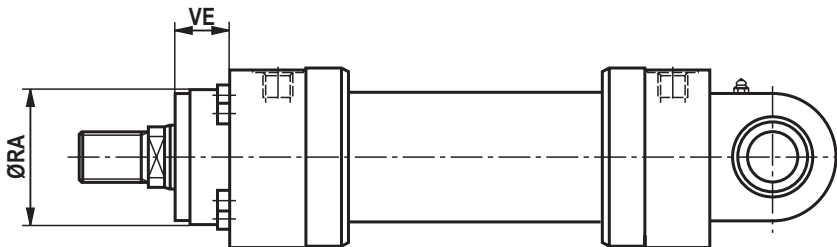

**Dimensions CDH3: MP3 (dimensions in mm)**

ØAL	ØMM	KK 5)	A 5)	KK 6)	A 6)	NV	ØD	ØDA	ØD4 2)	EE 4; 16)	EE 4; 17)	Y	PJ	X1	WA
40	28	M22x1.5	22	M24x2	35	22	92	52	34	G1/2	M22x1.5	91	120	43	18
50	36	M28x1.5	28	M30x2	45	30	108	62	34	G1/2	M22x1.5	90	120	51.5	18
63	45	M35x1.5	35	M39x3	55	36	140	78	42	G3/4	M27x2	117	133	67	22
80	56	M45x1.5	45	M50x3	75	46	148	100	42	G3/4	M27x2	124	146	71.5	22
100	70	M58x1.5	58	M64x3	95	60	186	125	47	G1	M33x2	119	171	90.5	25
125	90	M65x1.5	65	M80x3	110	75	235	160	58	G1 1/4	M42x2	170	205	114	32
140	100	M80x2	80	M90x3	120	85	258	175	58	G1 1/4	M42x2	186	219	126	35
160	110	M100x2	100	M100x3	140	95	292	200	65	G1 1/2	M48x2	210	240	142.5	40
180	125	M110x2	110	M110x4	150	110	325	220	65	G1 1/2	M48x2	241	264	159.5	45
200	140	M120x3	120	M120x4	160	120	350	245	65	G1 1/2	M48x2	262	278	172.5	45

ØAL	ØMM	XC	L	MR	M1	ØCD H11	EW h12	ØRA 7)	VE 7)	ØRA 8)	VE 8)
40	28	268	35	36	34	30	28	52	45	52	20
50	36	280	45	42	40	35	30	70	47	70	19
63	45	330	50	52	50	40	35	88	43	88	13
80	56	355	55	65	62.5	50	40	98	53	98	15
100	70	390	65	70	70	60	50	120	55	120	17
125	90	495	75	82	82	70	55	150	68	150	20
140	100	530	80	95	95	80	60	170	75	170	23
160	110	600	90	113	113	90	65	200	90	200	90
180	125	665	105	125	125	100	70	230	100	230	100
200	140	710	115	142.5	142.5	110	80	250	110	250	110

ØAL = Piston Ø

ØMM = Piston rod Ø

X\* = Stroke length

1) Bleeding: With view to the piston rod, the position is offset by 90° in relation to the line connection (clockwise)

2) Ø D4 max. 0.5 mm deep

3) Throttle valve only with end position cushioning "E" (180° for bleeding)

4) Flange connections see separate table pages 36 and 37

5) Thread design "G"

6) Thread design "A"

7) Dimensions for cylinders with seal design M, T, G, L, R, S and V

8) Dimensions for cylinders with seal design A and B

9) Standard version "W" Lubricating nipple, cone head form A according to DIN 71412

16) Line connection "B" and "C"

17) Line connection "M"

### Self-aligning clevis at base CDH3: MP5

#### CDH3 MP5

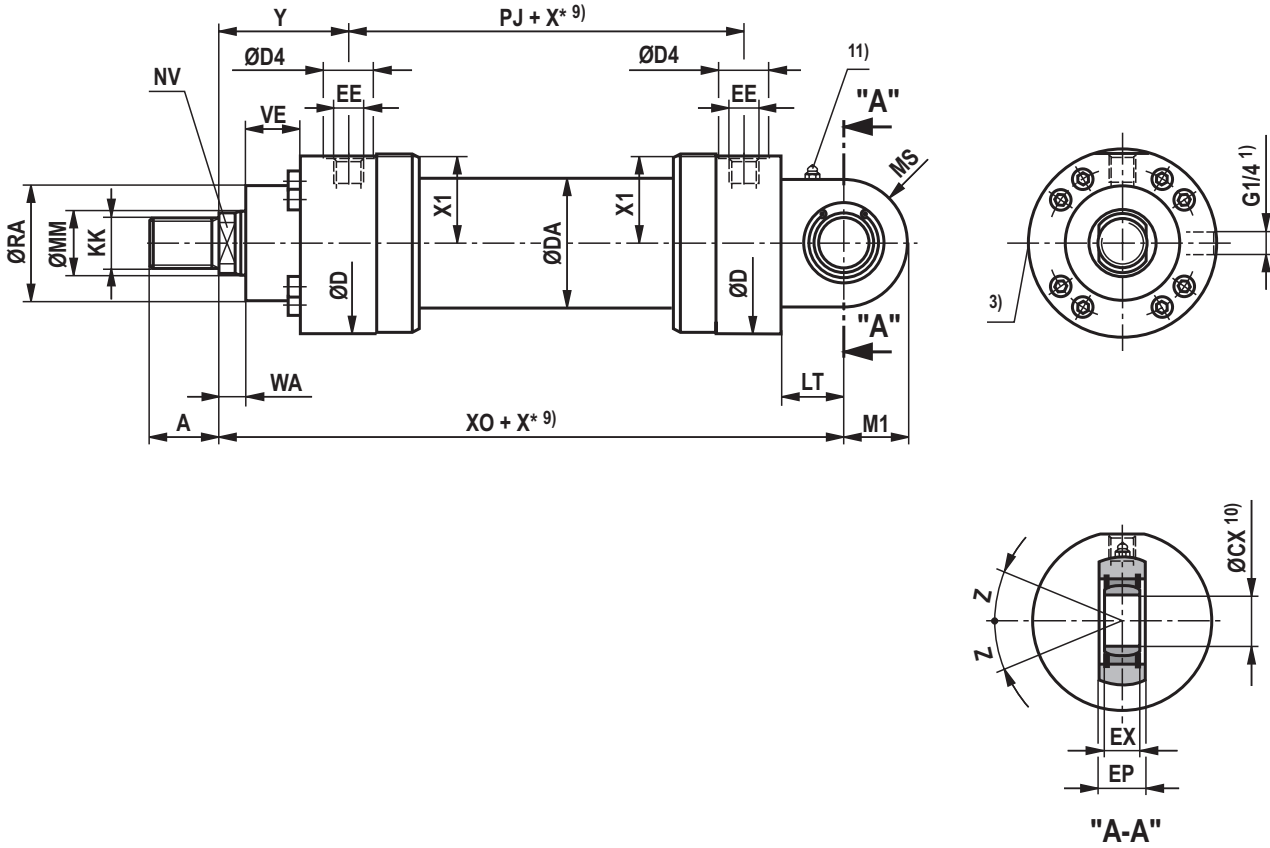

CDH3 MP5: With seal design "A", "B" and  $\text{ØAL}$  160 to 320 mm

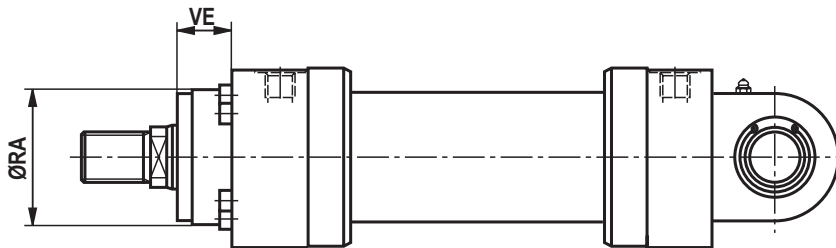

## Dimensions CDH3: MP5 (dimensions in mm)

ØAL	ØMM	KK 5)	A 5)	KK 6)	A 6)	NV	ØD	ØDA	ØD4 2)	EE 4; 16)	EE 4; 17)	Y	PJ	X1	WA	X0	X* min
40	28	M22x1.5	22	M24x2	35	22	92	52	34	G1/2	M22x1.5	91	120	43	18	268	-
50	36	M28x1.5	28	M30x2	45	30	108	62	34	G1/2	M22x1.5	90	120	51.5	18	280	-
63	45	M35x1.5	35	M39x3	55	36	140	78	42	G3/4	M27x2	117	133	67	22	330	-
80	56	M45x1.5	45	M50x3	75	46	148	100	42	G3/4	M27x2	124	146	71.5	22	355	-
100	70	M58x1.5	58	M64x3	95	60	186	125	47	G1	M33x2	119	171	90.5	25	390	-
125	90	M65x1.5	65	M80x3	110	75	235	160	58	G1 1/4	M42x2	170	205	114	32	495	-
140	100	M80x2	80	M90x3	120	85	258	175	58	G1 1/4	M42x2	186	219	126	35	530	-
160	110	M100x2	100	M100x3	140	95	292	200	65	G1 1/2	M48x2	210	240	142.5	40	600	-
180	125	M110x2	110	M110x4	150	110	325	220	65	G1 1/2	M48x2	241	264	159.5	45	665	-
200	140	M120x3	120	M120x4	160	120	350	245	65	G1 1/2	M48x2	262	278	172.5	45	710	-
220	160	M120x3	120	M120x4	160	140	375	292	65	G1 1/2	M48x2	262	326	185	40	760	-
250	180	M130x3	130	M150x4	190	160	440	324	65	G1 1/2	M48x2	272	336	218	40	825	20
280	200	-	-	M160x4	200	180	460	368	65	G1 1/2	M48x2	282	366	228	40	895	-
320	220	-	-	M180x4	220	200	490	406	65	G1 1/2	M48x2	287	391	243	40	965	340

ØAL	ØMM	C <sub>0</sub> <sup>18)</sup> kN	F <sub>adm</sub> <sup>19)</sup> kN	LT	M1	MS	ØCX	EP -0.4	EX	Z	ØRA 7)	VE 7)	ØRA 8)	VE 8)
40	28	106	38.2	35	34	36	30 <sub>-0.010</sub>	28	22 <sub>-0.12</sub>	6°	52	45	52	20
50	36	153	55.1	45	40	42	35 <sub>-0.012</sub>	30	25 <sub>-0.12</sub>	6°	70	47	70	19
63	45	250	90.0	50	50	52	40 <sub>-0.012</sub>	35	28 <sub>-0.12</sub>	7°	88	43	88	13
80	56	365	131.4	55	62.5	65	50 <sub>-0.012</sub>	40	35 <sub>-0.12</sub>	6°	98	53	98	15
100	70	400	144.0	65	70	70	60 <sub>-0.015</sub>	50	44 <sub>-0.15</sub>	6°	120	55	120	17
125	90	540	194.4	75	82	82	70 <sub>-0.015</sub>	55	49 <sub>-0.15</sub>	6°	150	68	150	20
140	100	670	241.2	80	95	95	80 <sub>-0.015</sub>	60	55 <sub>-0.15</sub>	6°	170	75	170	23
160	110	980	352.8	90	113	113	90 <sub>-0.020</sub>	65	60 <sub>-0.20</sub>	5°	200	90	200	90
180	125	1120	403.2	105	125	125	100 <sub>-0.020</sub>	70	70 <sub>-0.20</sub>	7°	230	100	230	100
200	140	1700	612.0	115	142.5	142.5	110 <sub>-0.020</sub>	80	70 <sub>-0.20</sub>	6°	250	110	250	110
220	160	1700	612.0	115	150 <sup>12)</sup>	140 <sup>12)</sup>	110 <sub>-0.020</sub>	80	70 <sub>-0.20</sub>	6°	275	125	275	125
250	180	2900	1044.0	140	188 <sup>12)</sup>	178 <sup>12)</sup>	120 <sub>-0.020</sub>	90	85 <sub>-0.20</sub>	6°	320	135	320	135
280	200	-	-	170	210 <sup>12)</sup>	200 <sup>12)</sup>	140 <sub>-0.025</sub>	100	90 <sub>-0.25</sub>	7°	335	150	335	150
320	220	-	-	200	260 <sup>12)</sup>	250 <sup>12)</sup>	160 <sub>-0.025</sub>	110	105 <sub>-0.25</sub>	8°	350	165	350	165

ØAL = Piston Ø

ØMM = Piston rod Ø

X\* = Stroke length

X\*min = Min. stroke length

With hydraulic cylinders with end position cushioning, observe the notice on page 59!

1) Bleeding: With view to the piston rod, the position is offset by 90° in relation to the line connection (clockwise)

2) Ø D4 max. 0.5 mm deep

3) Throttle valve only with end position cushioning "E" (180° for bleeding)

4) Flange connections see separate table pages 36 and 37

5) Thread design "G"

6) Thread design "A"

7) Dimensions for cylinders with seal design M, T, G, L, R, S and V

8) Dimensions for cylinders with seal design A and B

9) Observe the min. stroke length "X\*min"

10) Related bolt Ø m6;

Related bolt Ø j6 for maintenance-free spherical bearing

11) Standard version "W"

Lubricating nipple, cone head form A according to DIN 71412; not applicable to spherical bearing, maintenance-free "A"

12) The specified dimensions are maximum values, tolerance classes 342 according to ISO 9013 Thermal cutting

16) Line connection "B" and "C"

17) Line connection "M"

18) C<sub>0</sub> = Static load rating of the swivel head19) F<sub>adm</sub> = Max. admissible load of the swivel head for increasing or alternating loads

## Round flange at head CDH3/CGH3: MF3

### CDH3 MF3

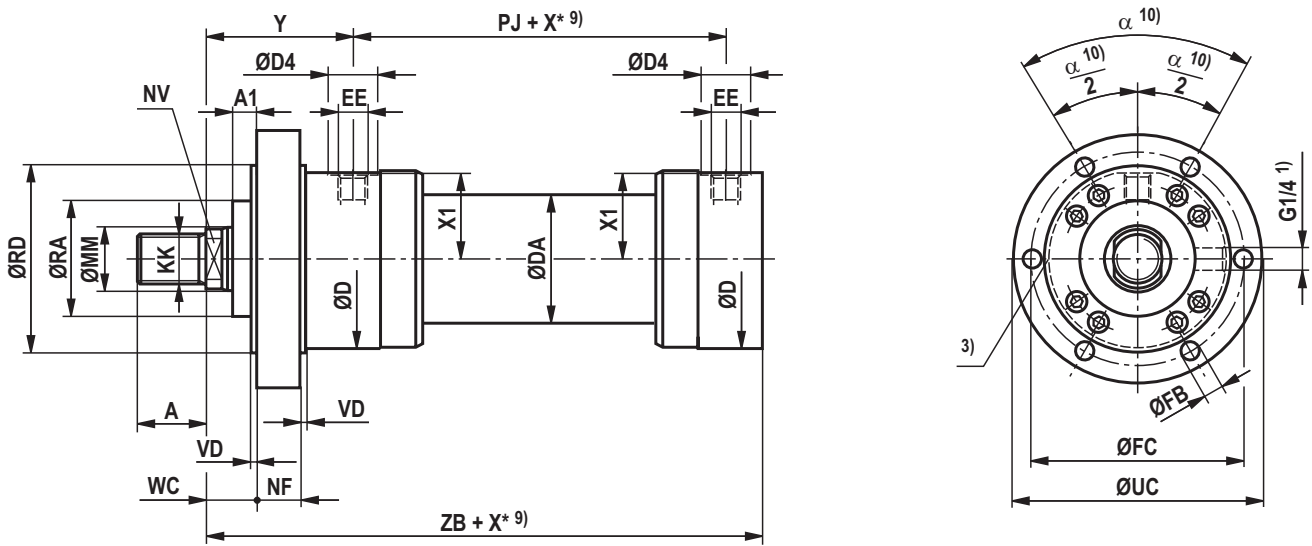

### CGH3 MF3

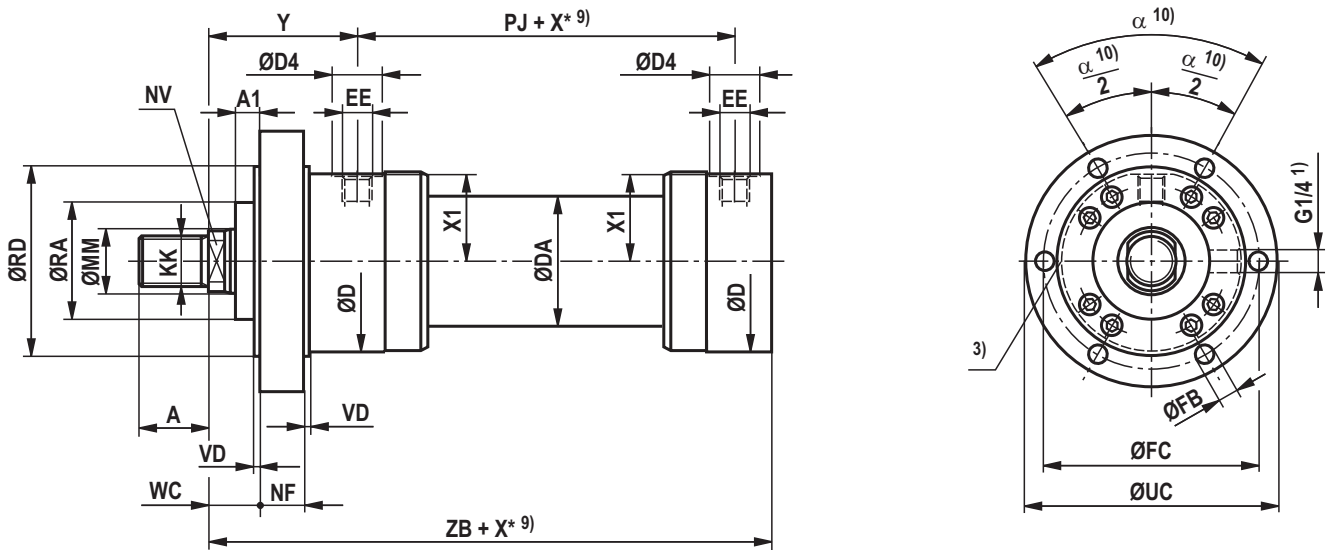

CGH3 MF3: With seal design "A", "B" and  $\text{ØAL}$  160 to 320 mm

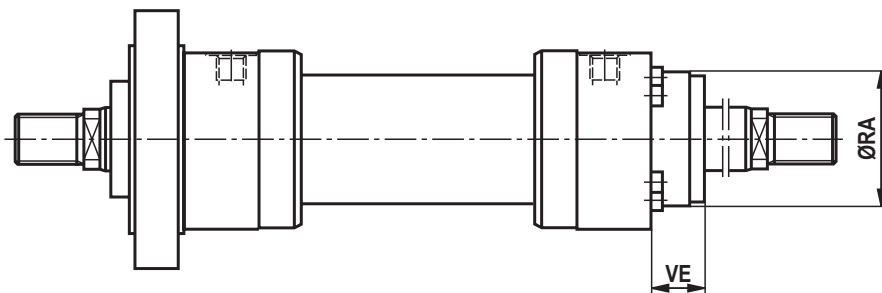



**Dimensions CDH3/CGH3: MF3 (dimensions in mm)**

ØAL	ØMM	KK 5)	A 5)	KK 6)	A 6)	NV	ØD	ØDA	ØD4 2)	EE 4; 16)	EE 4; 17)	Y	PJ	X1	ØRD e8	WC	VD
40	28	M22x1.5	22	M24x2	35	22	92	52	34	G1/2	M22x1.5	91	120	43	95	23	5
50	36	M28x1.5	28	M30x2	45	30	108	62	34	G1/2	M22x1.5	90	120	51.5	115	20	5
63	45	M35x1.5	35	M39x3	55	36	140	78	42	G3/4	M27x2	117	133	67	150	20	5
80	56	M45x1.5	45	M50x3	75	46	148	100	42	G3/4	M27x2	124	146	71.5	160	20	5
100	70	M58x1.5	58	M64x3	95	60	186	125	47	G1	M33x2	119	171	90.5	200	20	5
125	90	M65x1.5	65	M80x3	110	75	235	160	58	G1 1/4	M42x2	170	205	114	245	25	5
140	100	M80x2	80	M90x3	120	85	258	175	58	G1 1/4	M42x2	186	219	126	280	30	10
160	110	M100x2	100	M100x3	140	95	292	200	65	G1 1/2	M48x2	210	240	142.5	300	40	10
180	125	M110x2	110	M110x4	150	110	325	220	65	G1 1/2	M48x2	241	264	159.5	335	40	10
200	140	M120x3	120	M120x4	160	120	350	245	65	G1 1/2	M48x2	262	278	172.5	360	40	10
220	160	M120x3	120	M120x4	160	140	375	292	65	G1 1/2	M48x2	262	326	185	400	40	10
250	180	M130x3	130	M150x4	190	160	440	324	65	G1 1/2	M48x2	272	336	218	450	40	10
280	200	-	-	M160x4	200	180	460	368	65	G1 1/2	M48x2	282	366	228	470	50	10
320	220	-	-	M180x4	220	200	490	406	65	G1 1/2	M48x2	287	391	243	510	55	10

ØAL	ØMM	NF	PK	A1	ZB	ZM	X* min	ØFB H13	ØFC js13	ØUC -1	α	WA	ØRA 7)	VE 7)	ØRA 8)	VE 8)
40	28	35	120	0	238	302	-	13.5	120	145	60°	18	52	45	52	20
50	36	40	120	0	237	300	-	13.5	140	165	60°	18	70	47	70	19
63	45	40	133	0	285	367	-	17.5	180	210	60°	22	88	43	88	13
80	56	50	146	0	305	394	-	17.5	195	230	60°	22	98	53	98	15
100	70	55	171	0	330	409	-	22	230	270	60°	25	120	55	120	17
125	90	70	205	0	425	545	-	26	290	335	60°	32	150	68	150	20
140	100	70	219	0	457	591	-	30	330	380	60°	35	170	75	170	23
160	110	80	240	0	515	660	-	30	360	420	45°	40	200	90	200	90
180	125	95	264	0	565	746	-	36	400	470	45°	45	230	100	230	100
200	140	105	278	0	600	802	-	36	430	500	45°	45	250	110	250	110
220	160	115	326	0	655	850	-	39	475	550	45°	40	275	125	275	125
250	180	125	336	0	695	880	20	45	530	610	45°	40	320	135	320	135
280	200	130	366	0	735	930	-	45	550	630	45°	40	335	150	335	150
320	220	140	391	5	775	965	340	45	590	670	30°	40	350	165	350	165

ØAL = Piston Ø

ØMM = Piston rod Ø

X\* = Stroke length

X\*min = min. stroke length

With hydraulic cylinders with end position cushioning, observe the notice on page 59!

1) Bleeding: With view to the piston rod, the position is offset by 90° in relation to the line connection (clockwise)

2) Ø D4 max. 0.5 mm deep

3) Throttle valve only with end position cushioning "E" (180° for bleeding)

4) Flange connections see separate table pages 36 and 37

5) Thread design "G"

6) Thread design "A"

7) Dimensions for cylinders with seal design M, T, G, L, R, S and V

8) Dimensions for cylinders with seal design A and B

9) Observe the min. stroke length "X\*min"

10) With piston Ø 160 to 280 mm 8 mounting bores  
With piston Ø 320 mm 12 mounting bores

16) Line connection "B" and "C"

17) Line connection "M"

## Round flange at base CDH3: MF4

### CDH3 MF4

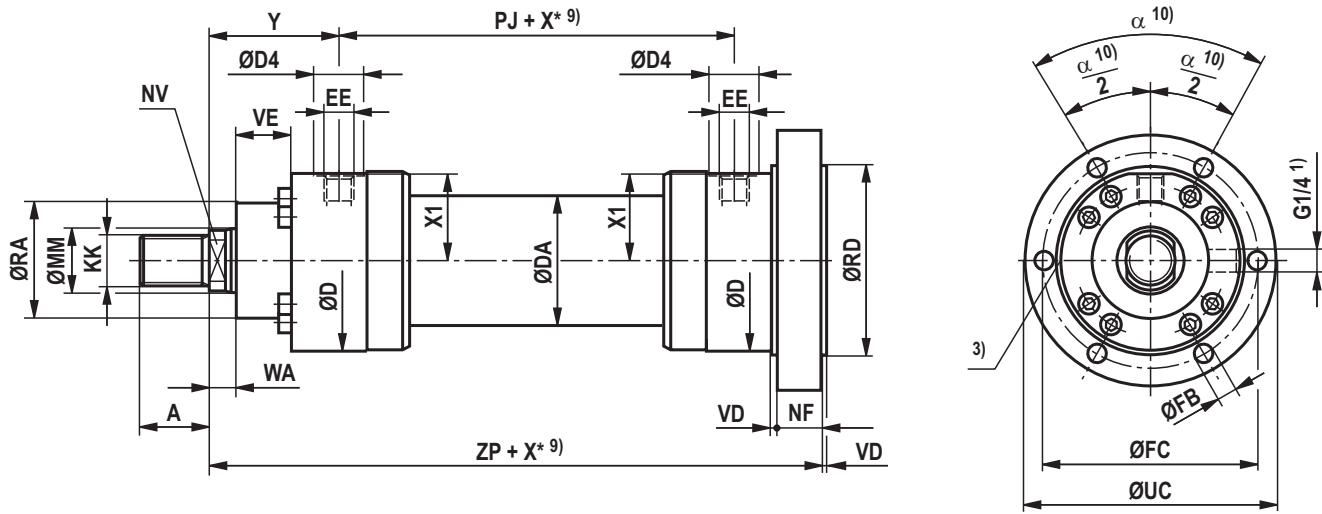

### CDH3 MF4: With seal design "A", "B" and $\varnothing AL$ 160 to 320 mm

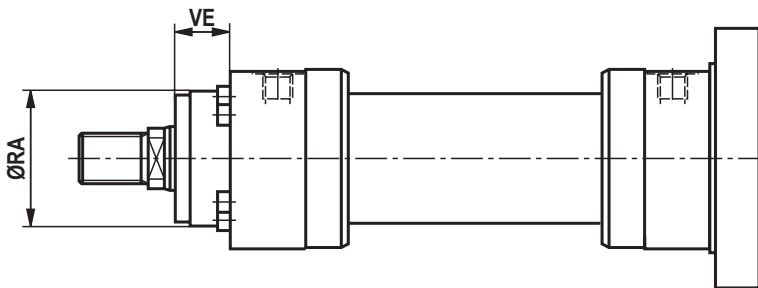

## Dimensions CDH3: MF4 (dimensions in mm)

ØAL	ØMM	KK 5)	A 5)	KK 6)	A 6)	NV	ØD	ØDA	ØD4 2)	EE 4; 16)	EE 4; 17)	Y	PJ	X1	WA
40	28	M22x1.5	22	M24x2	35	22	92	52	34	G1/2	M22x1.5	91	120	43	18
50	36	M28x1.5	28	M30x2	45	30	108	62	34	G1/2	M22x1.5	90	120	51.5	18
63	45	M35x1.5	35	M39x3	55	36	140	78	42	G3/4	M27x2	117	133	67	22
80	56	M45x1.5	45	M50x3	75	46	148	100	42	G3/4	M27x2	124	146	71.5	22
100	70	M58x1.5	58	M64x3	95	60	186	125	47	G1	M33x2	119	171	90.5	25
125	90	M65x1.5	65	M80x3	110	75	235	160	58	G1 1/4	M42x2	170	205	114	32
140	100	M80x2	80	M90x3	120	85	258	175	58	G1 1/4	M42x2	186	219	126	35
160	110	M100x2	100	M100x3	140	95	292	200	65	G1 1/2	M48x2	210	240	142.5	40
180	125	M110x2	110	M110x4	150	110	325	220	65	G1 1/2	M48x2	241	264	159.5	45
200	140	M120x3	120	M120x4	160	120	350	245	65	G1 1/2	M48x2	262	278	172.5	45
220	160	M120x3	120	M120x4	160	140	375	292	65	G1 1/2	M48x2	262	326	185	40
250	180	M130x3	130	M150x4	190	160	440	324	65	G1 1/2	M48x2	272	336	218	40
280	200	–	–	M160x4	200	180	460	368	65	G1 1/2	M48x2	282	366	228	40
320	220	–	–	M180x4	220	200	490	406	65	G1 1/2	M48x2	287	391	243	40

ØAL	ØMM	ZP	X* min	NF	VD	ØRD e8	ØFB H13	ØFC js13	ØUC -1	α	ØRA 7)	VE 7)	ØRA 8)	VE 8)
40	28	273	–	35	5	95	13.5	120	145	60°	52	45	52	20
50	36	277	–	40	5	115	13.5	140	165	60°	70	47	70	19
63	45	325	–	40	5	150	17.5	180	210	60°	88	43	88	13
80	56	355	–	50	5	160	17.5	195	230	60°	98	53	98	15
100	70	385	–	55	5	200	22	230	270	60°	120	55	120	17
125	90	495	–	70	5	245	26	290	335	60°	150	68	150	20
140	100	532	–	70	10	280	30	330	380	60°	170	75	170	23
160	110	600	–	80	10	300	30	360	420	45°	200	90	200	90
180	125	665	–	95	10	335	36	400	470	45°	230	100	230	100
200	140	710	–	105	10	360	36	430	500	45°	250	110	250	110
220	160	770	–	115	10	400	39	475	550	45°	275	125	275	125
250	180	820	20	125	10	450	45	530	610	45°	320	135	320	135
280	200	865	–	130	10	470	45	550	630	45°	335	150	335	150
320	220	915	340	140	10	510	45	590	670	30°	350	165	350	165

ØAL = Piston Ø

ØMM = Piston rod Ø

X\* = Stroke length

X\*min = Min. stroke length

With hydraulic cylinders with end position cushioning, observe the notice on page 59!

1) Bleeding: With view to the piston rod, the position is offset by 90° in relation to the line connection (clockwise)

2) Ø D4 max. 0.5 mm deep

3) Throttle valve only with end position cushioning "E" (180° for bleeding)

4) Flange connections see separate table pages 36 and 37

5) Thread design "G"

6) Thread design "A"

7) Dimensions for cylinders with seal design M, T, G, L, R, S and V

8) Dimensions for cylinders with seal design A and B

9) Observe the min. stroke length "X\*min"

10) With piston Ø 160 to 280 mm 8 mounting bores  
With piston Ø 320 mm 12 mounting bores

16) Line connection "B" and "C"

17) Line connection "M"

# Trunnion CDH3/CGH3: MT4

## CDH3 MT4

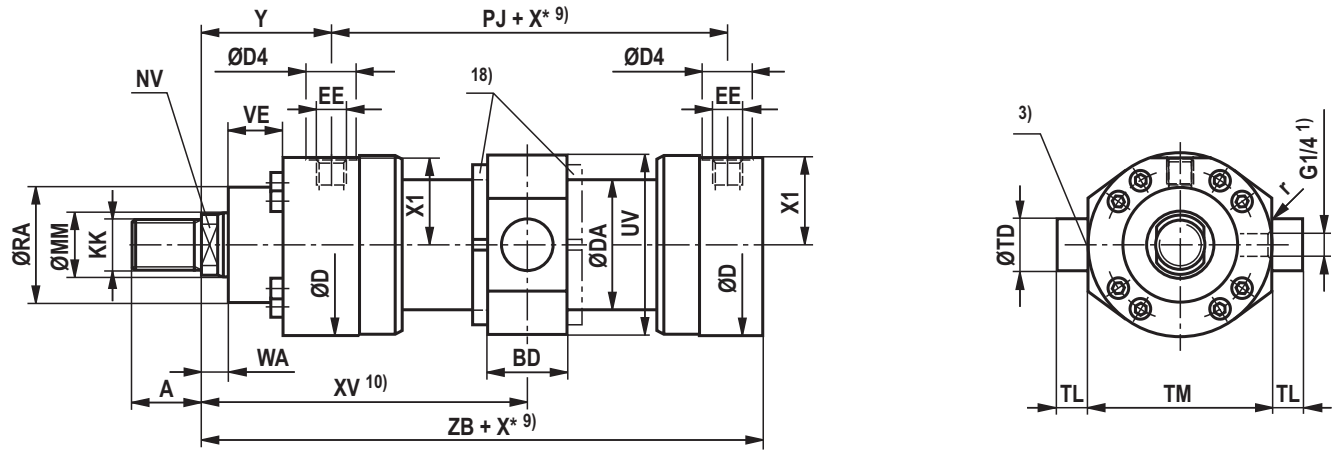

CDH3 MT4: With seal design "A", "B" and ØAL 160 to 320 mm

Dimensions for cylinder with piston rod extension "LY" in retracted condition

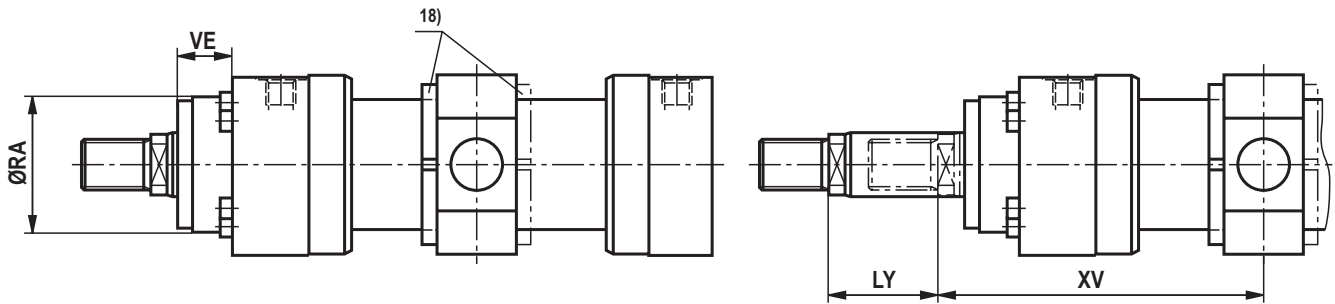

## CGH3 MT4

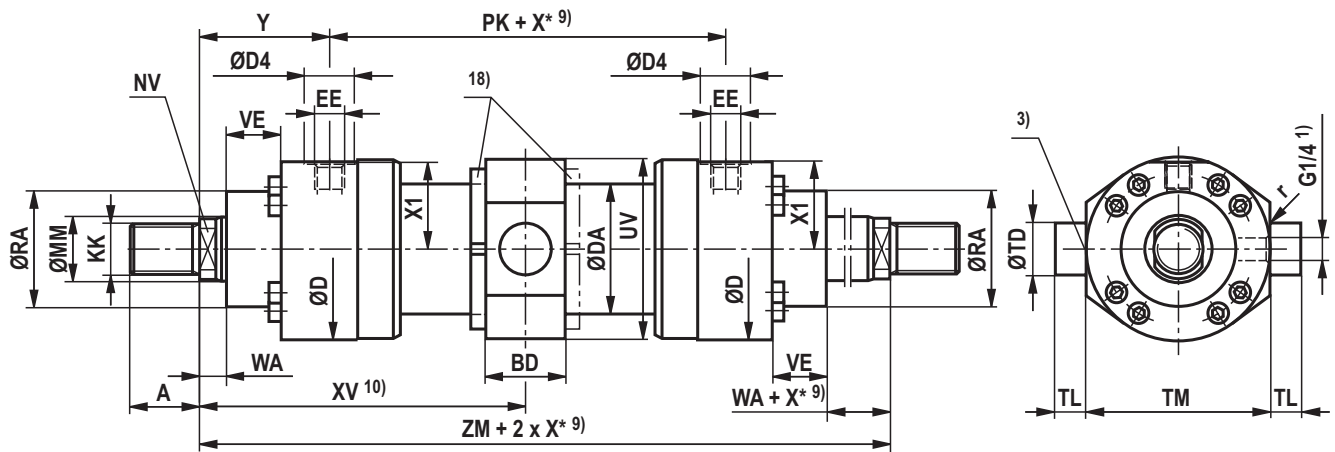

CGH3 MT4: With seal design "A", "B" and ØAL 160 to 320 mm

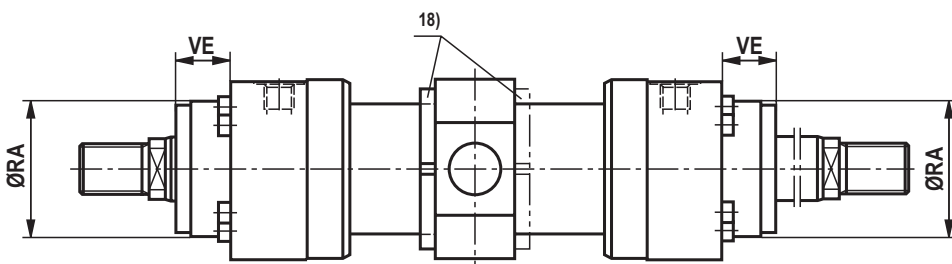

## Dimensions CDH3/CGH3: MT4 (dimensions in mm)

ØAL	ØMM	KK 5)	A 5)	KK 6)	A 6)	NV	ØD	ØDA	ØD4 2)	EE 4; 16)	EE 4; 17)	Y	PJ	X1	WA	PK	ZB
40	28	M22x1.5	22	M24x2	35	22	92	52	34	G1/2	M22x1.5	91	120	43	18	120	238
50	36	M28x1.5	28	M30x2	45	30	108	62	34	G1/2	M22x1.5	90	120	51.5	18	120	237
63	45	M35x1.5	35	M39x3	55	36	140	78	42	G3/4	M27x2	117	133	67	22	133	285
80	56	M45x1.5	45	M50x3	75	46	148	100	42	G3/4	M27x2	124	146	71.5	22	146	305
100	70	M58x1.5	58	M64x3	95	60	186	125	47	G1	M33x2	119	171	90.5	25	171	330
125	90	M65x1.5	65	M80x3	110	75	235	160	58	G1 1/4	M42x2	170	205	114	32	205	425
140	100	M80x2	80	M90x3	120	85	258	175	58	G1 1/4	M42x2	186	219	126	35	219	457
160	110	M100x2	100	M100x3	140	95	292	200	65	G1 1/2	M48x2	210	240	142.5	40	240	515
180	125	M110x2	110	M110x4	150	110	325	220	65	G1 1/2	M48x2	241	264	159.5	45	264	565
200	140	M120x3	120	M120x4	160	120	350	245	65	G1 1/2	M48x2	262	278	172.5	45	278	600
220	160	M120x3	120	M120x4	160	140	375	292	65	G1 1/2	M48x2	262	326	185	40	326	655
250	180	M130x3	130	M150x4	190	160	440	324	65	G1 1/2	M48x2	272	336	218	40	336	695
280	200	-	-	M160x4	200	180	460	368	65	G1 1/2	M48x2	282	366	228	40	366	735
320	220	-	-	M180x4	220	200	490	406	65	G1 1/2	M48x2	287	391	243	40	391	775

ØAL	ØMM	ZM	X* min	XV 11) cent	XV min	XV max	BD	UV 12)	ØTD e8	TL js16	TM h12	r	ØRA 7)	VE 7)	ØRA 8)	VE 8)
40	28	302	42	151+X*/2	172	138+X*	48	101	40	30	95	2	52	45	52	20
50	36	300	50	150+X*/2	175	134+X*	48	117	40	30	120	2	70	47	70	19
63	45	367	64	183.5+X*/2	215.5	163.5+X*	53	153	45	35	150	2	88	43	88	13
80	56	384	82	197+X*/2	238	168+X*	68	169	55	50	160	2	98	53	98	15
100	70	409	109	204.5+X*/2	259	165+X*	88	203	60	55	200	2	120	55	120	17
125	90	545	131	272.5+X*/2	338	207+X*	118	252	75	60	245	2.5	150	68	150	20
140	100	591	147	295.5+X*/2	369	222+X*	128	282	85	70	280	2.5	170	75	170	23
160	110	660	186	330+X*/2	423	237+X*	148	310	95	80	300	2.5	200	90	200	90
180	125	746	212	373+X*/2	479	267+X*	168	348	110	90	335	2.5	230	100	230	100
200	140	802	228	401+X*/2	515	287+X*	188	373	120	100	360	2.5	250	110	250	110
220	160	850	205	425+X*/2	527.5	322.5+X*	165	398	130	100	400	2.5	275	125	275	125
250	180	880	245	440+X*/2	562.5	317.5+X*	175	463	140	100	450	5	320	135	320	135
280	200	930	245	465+X*/2	587.5	342.5+X*	205	486	170	125	480	5	335	150	335	150
320	220	965	600	482.5+X*/2	782.5	182.5+X*	245	537	200	150	500	5	350	165	350	165

ØAL = Piston Ø

ØMM = Piston rod Ø

X\* = Stroke length

X\*min = Min. stroke length

With hydraulic cylinders with end position cushioning, observe the notice on page 59!

1) Bleeding: With view to the piston rod, the position is offset by 90° in relation to the line connection (clockwise)

2) Ø D4 max. 0.5 mm deep

3) Throttle valve only with end position cushioning "E" (180° for bleeding)

4) Flange connections see separate table pages 36 and 37

5) Thread design "G"

6) Thread design "A"

7) Dimensions for cylinders with seal design M, T, G, L, R, S and V

8) Dimensions for cylinders with seal design A and B

9) Observe the min. stroke length "X\*min"

10) When ordering, always specify the "XV" dimension in the plain text. Preferred XV dimension: Observe the trunnion position in the cylinder center XVmin and XVmax

11) XVcent recommendation: Trunnion position in cylinder center

12) The specified dimensions are maximum values, tolerance classes 342 according to ISO 9013 Thermal cutting

16) Line connection "B" and "C"

17) Line connection "M"

18) Trunnion nut with ØAL ≥ 125 mm either at head or at base side depending on the position of the trunnion (XV)

**Important installation information:** During installation, it must be ensured that the trunnion bearings are installed up to the trunnion shoulders. Any variation may reduce the product's service life.

## Foot mounting CDH3/CGH3: MS2

### CDH3 MS2

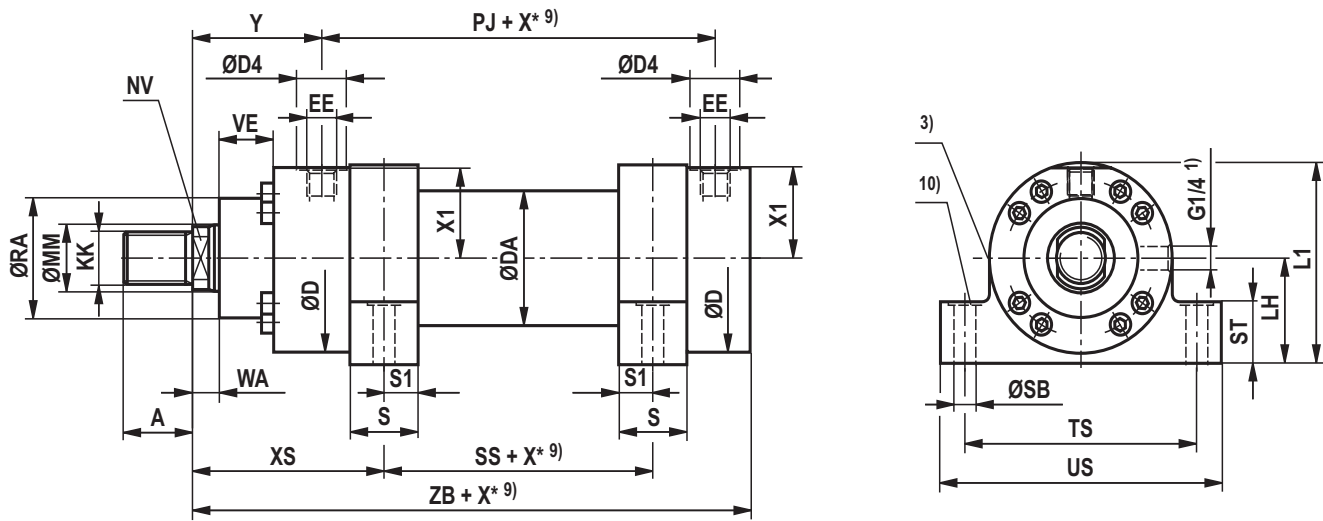

CDH3 MS2. With seal design "A", "B" and  $\text{ØAL}$  160 to 320 mm

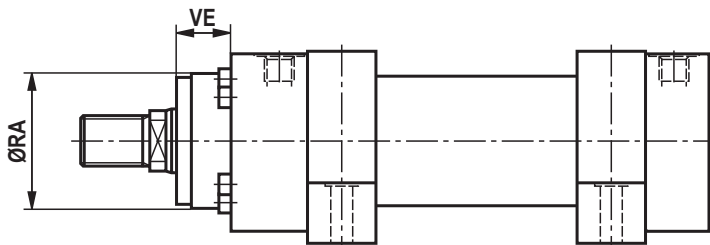

### CGH3 MS2

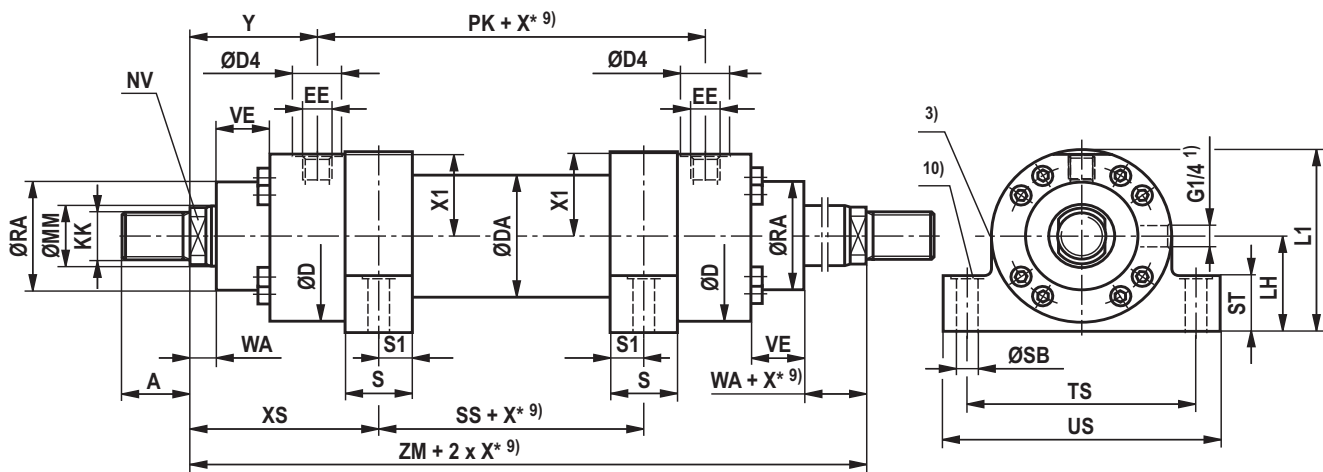

CGH3 MS2: With seal design "A", "B" and  $\text{ØAL}$  160 to 320 mm

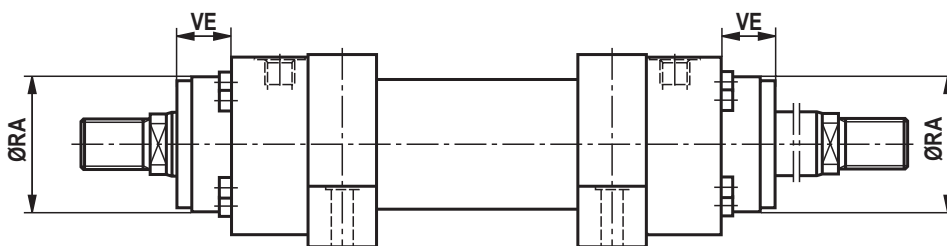



## Dimensions CDH3/CGH3: MS2 (dimensions in mm)

ØAL	ØMM	KK 5)	A 5)	KK 6)	A 6)	NV	ØD	ØDA	ØD4 2)	EE 4; 16)	EE 4; 17)	Y	PJ	X1	WA	PK	XS
40	28	M22x1.5	22	M24x2	35	22	92	52	34	G1/2	M22x1.5	91	120	43	18	120	126
50	36	M28x1.5	28	M30x2	45	30	108	62	34	G1/2	M22x1.5	90	120	51.5	18	120	130
63	45	M35x1.5	35	M39x3	55	36	140	78	42	G3/4	M27x2	117	133	67	22	133	164
80	56	M45x1.5	45	M50x3	75	46	148	100	42	G3/4	M27x2	124	146	71.5	22	146	176
100	70	M58x1.5	58	M64x3	95	60	186	125	47	G1	M33x2	119	171	90.5	25	171	179
125	90	M65x1.5	65	M80x3	110	75	235	160	58	G1 1/4	M42x2	170	205	114	32	205	245
140	100	M80x2	80	M90x3	120	85	258	175	58	G1 1/4	M42x2	186	219	126	35	219	265.5
160	110	M100x2	100	M100x3	140	95	292	200	65	G1 1/2	M48x2	210	240	142.5	40	240	302.5
180	125	M110x2	110	M110x4	150	110	325	220	65	G1 1/2	M48x2	241	264	159.5	45	264	353.5
200	140	M120x3	120	M120x4	160	120	350	245	65	G1 1/2	M48x2	262	278	172.5	45	278	379.5
220	160	M120x3	120	M120x4	160	140	375	292	65	G1 1/2	M48x2	262	326	185	40	326	387.5
250	180	M130x3	130	M150x4	190	160	440	324	65	G1 1/2	M48x2	272	336	218	40	336	397.5
280	200	-	-	M160x4	200	180	460	368	65	G1 1/2	M48x2	282	366	228	40	366	410
320	220	-	-	M180x4	220	200	490	406	65	G1 1/2	M48x2	287	391	243	40	391	440

ØAL	ØMM	ZB	ZM	SS	X* min	S	S1	ØSB H13	ST	TS js13	US 12)	LH	L1 12)	ØRA 7)	VE 7)	ØRA 8)	VE 8)
40	28	238	302	50	-	30	15	17.5	32	125	164	50	100	52	45	52	20
50	36	237	300	40	4	40	20	22	37	150	197	60	118	70	47	70	19
63	45	285	367	39	15	50	25	24	47	185	235	75	149	88	43	88	13
80	56	305	394	42	22	60	30	26	52	210	270	80	160	98	53	98	15
100	70	330	409	51	23	70	35	33	62	250	320	100	200	120	55	120	17
125	90	425	545	55	39	90	45	40	72	310	392	120	245	150	68	150	20
140	100	457	591	60	39	95	47.5	40	77	340	422	135	271	170	75	170	23
160	110	515	660	55	64	115	57.5	45	87	370	462	150	305	200	90	200	90
180	125	565	746	39	110	145	72.5	45	79	415	515	165	337	230	100	230	100
200	140	600	802	43	116	155	77.5	52	112	460	570	180	366	250	110	250	110
220	160	655	850	75	100	155	77.5	52	112	500	610	200	398	275	125	275	125
250	180	695	880	85	90	155	77.5	52	122	550	660	225	456	320	135	320	135
280	200	735	930	110	70	160	80	62	142	600	722	235	476	335	150	335	150
320	220	775	965	85	400	190	95	74	162	650	785	255	512	350	165	350	165

ØAL = Piston Ø

ØMM = Piston rod Ø

X\* = Stroke length

X\*min = Min. stroke length

With hydraulic cylinders with end position cushioning, observe the notice on page 59!

1) Bleeding: With view to the piston rod, the position is offset by 90° in relation to the line connection (clockwise)

2) Ø D4 max. 0.5 mm deep

3) Throttle valve only with end position cushioning "E" (180° for bleeding)

4) Flange connections see separate table pages 36 and 37

5) Thread design "G"

6) Thread design "A"

7) Dimensions for cylinders with seal design M, T, G, L, R, S and V

8) Dimensions for cylinders with seal design A and B

9) Observe the min. stroke length "X\*min"

10) Recess 2 mm deep, for hexagon socket head cap screws; ISO 4762 (for piston Ø 320 mm DIN 931) – The screws must not be subjected to shear force. Force distribution via additional external fitting strip.

12) The specified dimensions are maximum values, tolerance classes 342 according to ISO 9013 Thermal cutting

16) Line connection "B" and "C"

17) Line connection "M"

### Ordering code series CSH3

CS	H3	/	/	/	A	3X	/								Z
----	----	---	---	---	---	----	---	--	--	--	--	--	--	--	---

**Differential cylinder with position measurement system** <sup>18)</sup> = CS

**Series** = H3

**Types of mounting**

Swivel eye at base <sup>1)</sup> = MP3  
 Self-aligning clevis at base = MP5  
 Round flange at head = MF3  
 Round flange at base = MF4  
 Trunnion <sup>2)</sup> = MT4  
 Foot mounting = MS2

**Piston Ø (ØAL) 40 to 320 mm**

**Piston rod Ø (ØMM) 28 to 220 mm**

**Stroke length in mm** <sup>3)</sup>

**Design principle**  
 Head and base flanged = A

**Component series**  
 30 to 39 unchanged installation and connection dimensions = 3X

**Line connection / version**

according to ISO 1179-1 (pipe thread ISO 228-1) = B  
 according to ISO 9974-1 (metric thread ISO 261) = M  
 Flange porting pattern according to ISO 6162-2 tab. 2 type 1 (SAE 6000 PSI) <sup>4), 25)</sup> = D  
 Flange porting pattern according to ISO 6164 tab. 2 according to ISO 1179-1 (pipe thread ISO 228-1) with flat pipe flange <sup>4)</sup> = H <sup>31)</sup> = C

**for directional and high-response valves**

Subplate NG6 <sup>4) 5) 27)</sup> = P  
 Subplate NG10 <sup>4) 6) 27)</sup> = T  
 Subplate NG16 <sup>4) 7) 27)</sup> = U  
 Subplate NG25 <sup>4) 7) 27)</sup> = V

**for SL and SV valves**

Subplate NG6 <sup>4) 5) 15) 27)</sup> = A  
 Subplate NG10 <sup>4) 6) 15) 27)</sup> = E  
 Subplate NG20 <sup>4) 7) 15) 27)</sup> = L  
 Subplate NG30 <sup>4) 7) 15) 27)</sup> = N

**Line connection/position at head**

View to piston rod

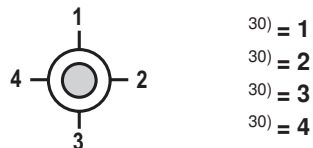

**Option**  
**Z =** Additional options, fill fields for additional options

**Seal design**

**For mineral oil HL, HLP and HFA**

**M =** <sup>29)</sup> Standard seal system  
**L =** Standard seal system with guide rings  
**R =** <sup>29)</sup> Reduced friction heavy industry

**For mineral oil HL, HLP, HFA and water glycol HFC**

**G =** <sup>27) 29)</sup> Standard seal system HFC  
**T =** <sup>29)</sup> Servo quality/reduced friction

**For phosphate ester HFD-R and polyol ester HFD-U**

**S =** <sup>29)</sup> Servo quality/reduced friction  
**V =** <sup>27) 29)</sup> Standard seal system FKM

**End position cushioning**

**U =** Without  
**E =** <sup>20)</sup> On both sides, adjustable

**Piston rod end**

**A =** Thread for swivel head CGAS  
**G =** <sup>26)</sup> Thread for swivel head CGA, CGAK, plain clevis CSA  
**S =** With mounted swivel head CGAS  
**L =** <sup>26)</sup> With mounted swivel head CGA  
**M =** <sup>26)</sup> With mounted swivel head CGAK  
**N =** <sup>1)</sup> With mounted plain clevis CSA

**Piston rod design**

**C =** Hard chromium-plated  
**H =** <sup>11)</sup> Hardened and hard chromium-plated

**Line connection/position at base**

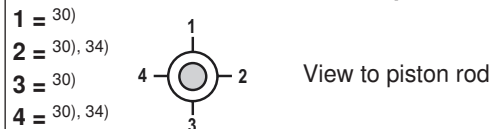

## Ordering code series CSH3

### Additional options

Fields for additional options

Z	T										
---	---	--	--	--	--	--	--	--	--	--	--

Position measurement system (magnetostrictive) without mating connector Mating connector - separate order, see page 47, 49	= T
Analog output 4-20 mA	= C
Analog output 0-10 V	= F
Digital output SSI	= D
Profibus D63	= N
Profibus D53	= P
Without measuring coupling	= W
Measuring coupling, on both sides	= A
Standard conical grease nipples, DIN 71412 form A	= W
Spherical bearing, maintenance-free	<sup>14), 35)</sup> = A
Flanged grease nipples, DIN 3404 form A	= B

W =	without test certificate
C =	with acceptance test certificate 3.1 based on EN 10204
W =	without oil filling
F =	with oil filling
W =	Priming class CP3
B = <sup>21)</sup>	Painting class CP4
L = <sup>21)</sup>	Painting class CP5
U = <sup>21)</sup>	Painting class CP6
E = <sup>21)</sup>	Painting class CP7
W =	without piston rod extension
Y =	Specify the piston rod extension LY in the plain text in mm

### Order examples:

**With additional options:** CSH3MP5/100/70/300A3X/B11CAUMZ TFAWW WWW

- |   |  |
|---|--|
| <ul style="list-style-type: none"> <li>1) Only piston Ø 40 to 200 mm</li> <li>2) Trunnion position freely selectable. When ordering, always specify the "XV" dimensions in the plain text in mm</li> <li>3) Observe the max. stroke length available, page 4, and the admissible stroke length (according to kinking calculation) on pages 56 to 58</li> <li>4) Not possible with MF4</li> <li>5) Piston Ø 40 to 80 mm, only position 11, subplates only possible in combination with line connection "B" at the head</li> <li>6) Piston Ø 63 to 200 mm, only position 11, subplates only possible in combination with line connection "B" at the head</li> <li>7) Piston Ø 125 to 200 mm, only position 11, subplates only possible in combination with line connection "B" at the head</li> </ul> | <ul style="list-style-type: none"> <li>14) Not possible with plain clevis "N"</li> <li>15) Subplates for SL and SV valves (isolator valves) Note: Seal designs T, G, L, R, S and V are not designed for the static holding function!</li> <li>18) Not standardized</li> <li>20) Possible from piston rod Ø 45 mm</li> <li>21) Specify RAL color in the plain text</li> <li>25) Only piston Ø 63 to 320 mm</li> <li>26) Only piston Ø 40 to 250 mm</li> <li>27) Maximum operating pressure 315 bar</li> <li>29) With CSH, by default with guide belts</li> <li>30) All graphical representations in the data sheet show position 1</li> <li>31) With MS2, only position 11 is possible</li> <li>34) With MF4 and line connection B, M or C not possible</li> <li>35) Not possible with MP3</li> </ul> |
|---|--|

### Overview types of mounting: Series CSH3

**CSH3 MP3**  
see page 24, 25



**CSH3 MP5**  
see page 26, 27



**CSH3 MF3**  
see page 28, 29



**CSH3 MF4**  
see page 30, 31

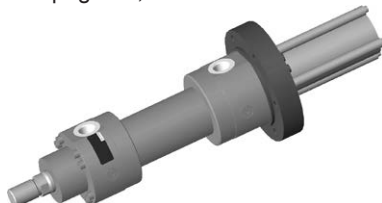

**CSH3 MT4**  
see page 32, 33

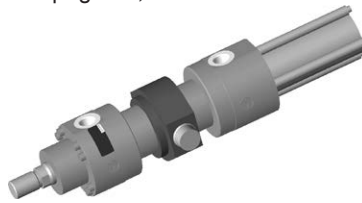

**CSH3 MS2**  
see page 34, 35



### Swivel eye at base CSH3: MP3

CSH3 MP3; ØAL 40 to 200 mm

for position measurement system output "C", "F" and "D"

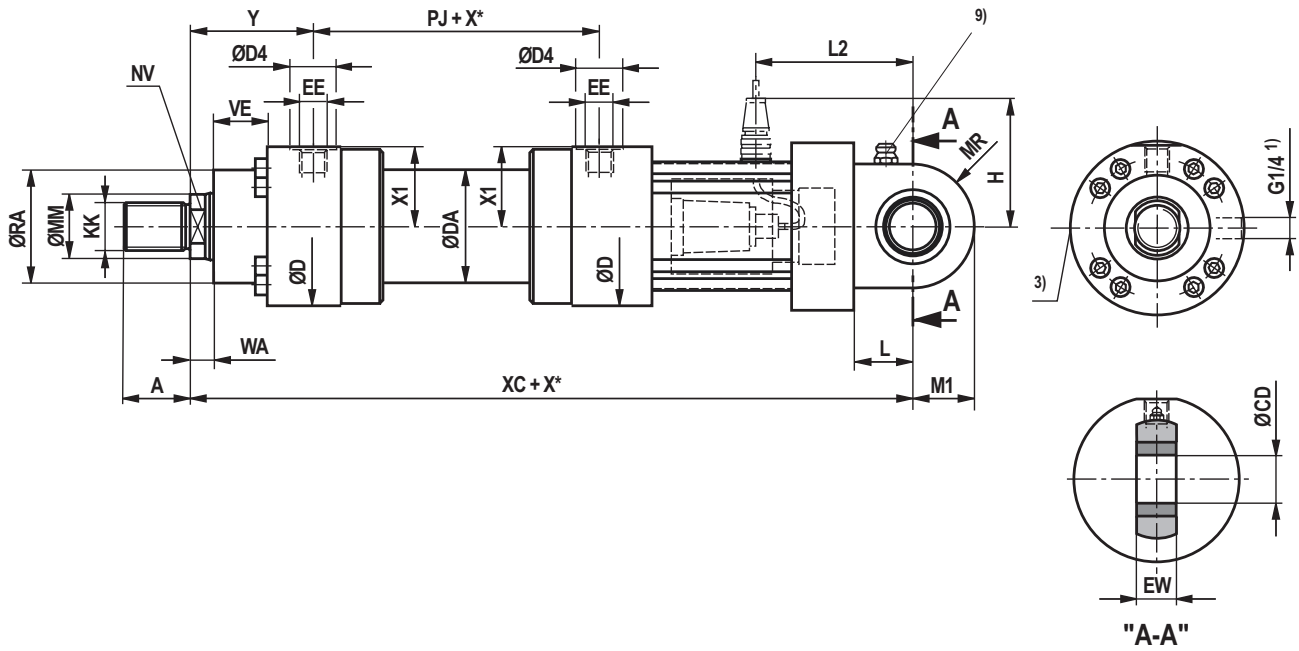

CSH3 MP3; ØAL 40 to 200 mm

for position measurement system output "N" and "P"

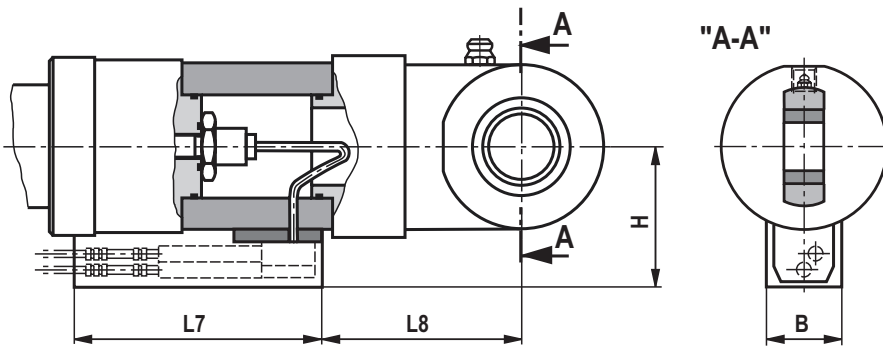

**Dimensions CSH3: MP3 (dimensions in mm)**

ØAL	ØMM	KK 5)	A 5)	KK 6)	A 6)	NV	ØD	ØDA	ØD4 2)	EE 4; 16)	EE 4; 17)	Y	PJ	X1	WA	X* max
40	28	M22x1.5	22	M24x2	35	22	92	52	34	G1/2	M22x1.5	91	120	43	18	1000
50	36	M28x1.5	28	M30x2	45	30	108	62	34	G1/2	M22x1.5	90	120	51.5	18	1000
63	45	M35x1.5	35	M39x3	55	36	140	78	42	G3/4	M27x2	117	133	67	22	2000
80	56	M45x1.5	45	M50x3	75	46	148	100	42	G3/4	M27x2	124	146	71.5	22	2000
100	70	M58x1.5	58	M64x3	95	60	186	125	47	G1	M33x2	119	171	90.5	25	3000
125	90	M65x1.5	65	M80x3	110	75	235	160	58	G1 1/4	M42x2	170	205	114	32	3000
140	100	M80x2	80	M90x3	120	85	258	175	58	G1 1/4	M42x2	186	219	126	35	3000
160	110	M100x2	100	M100x3	140	95	292	200	65	G1 1/2	M48x2	210	240	142.5	40	3000
180	125	M110x2	110	M110x4	150	110	325	220	65	G1 1/2	M48x2	241	264	159.5	45	3000
200	140	M120x3	120	M120x4	160	120	350	245	65	G1 1/2	M48x2	262	278	172.5	45	3000

ØAL	ØMM	XC	L	MR	M1	ØCD H11	EW h12	ØRA	VE	L2	L7	L8	H 13)	H 14)	B
40	28	433	35	36	34	30	28	52	45	102	200	83	108	115	64
50	36	445	45	42	40	35	30	70	47	115	200	102	116	125	64
63	45	508	50	52	50	40	35	88	43	127	200	104	133	140	64
80	56	540	55	65	62.5	50	40	98	53	137	200	109	137	125	64
100	70	565	65	70	70	60	50	120	55	155	200	127	156	135	64
125	90	668	75	82	82	70	55	150	68	185	200	161	181	150	64
140	100	705	80	95	95	80	60	170	75	192	200	166	192	160	64
160	110	785	90	113	113	90	65	200	90	225	200	193	210	170	64
180	125	838	105	125	125	100	70	230	100	235	200	202	226	180	64
200	140	888	115	142.5	142.5	110	80	250	110	245	200	214	239	195	64

ØAL = Piston Ø

ØMM = Piston rod Ø

X\* = Stroke length

X\*max = Max. stroke length

1) Bleeding: With view to the piston rod, the position is offset by 90° in relation to the line connection (clockwise)

2) Ø D4 max. 0.5 mm deep

3) Throttle valve only with end position cushioning "E" (180° for bleeding)

4) Flange connections see separate table pages 36 and 37

5) Thread design "G"

6) Thread design "A"

9) Standard version "W"

Lubricating nipple, cone head form A according to DIN 71412

13) Dimensions for position transducer output "N" and "P"

14) Dimensions for position transducer output "C", "F" and "D"

16) Line connection "B" and "C"

17) Line connection "M"

### Self-aligning clevis at base CSH3: MP5

#### CSH3 MP5

for position measurement system output "C", "F" and "D"

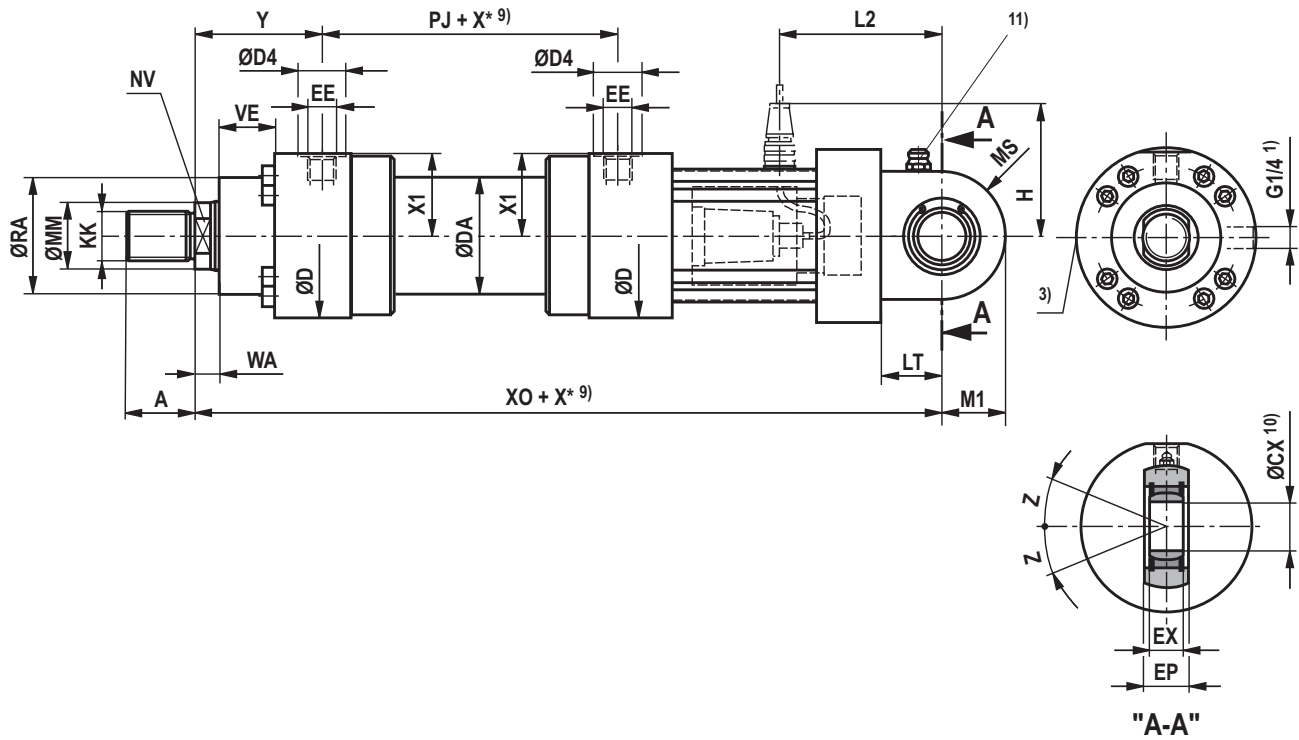

#### CSH3 MP5

for position measurement system output "N" and "P"

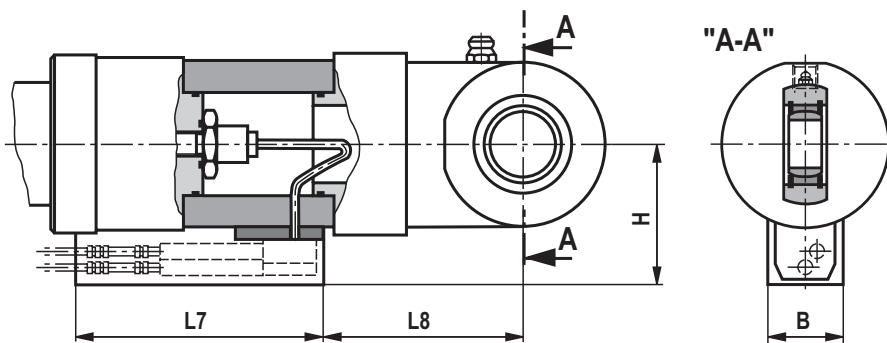



## Dimensions CSH3: MP5 (dimensions in mm)

ØAL	ØMM	KK 5)	A 5)	KK 6)	A 6)	NV	ØD	ØDA	ØD4 2)	EE 4;16)	EE 4;17)	Y	PJ	X1	WA	XO	X* min	C <sub>0</sub> <sup>18)</sup> kN
40	28	M22x1.5	22	M24x2	35	22	92	52	34	G1/2	M22x1.5	91	120	43	18	433	-	106
50	36	M28x1.5	28	M30x2	45	30	108	62	34	G1/2	M22x1.5	90	120	51.5	18	445	-	153
63	45	M35x1.5	35	M39x3	55	36	140	78	42	G3/4	M27x2	117	133	67	22	508	-	250
80	56	M45x1.5	45	M50x3	75	46	148	100	42	G3/4	M27x2	124	146	71.5	22	540	-	365
100	70	M58x1.5	58	M64x3	95	60	186	125	47	G1	M33x2	119	171	90.5	25	565	-	400
125	90	M65x1.5	65	M80x3	110	75	235	160	58	G1 1/4	M42x2	170	205	114	32	668	-	540
140	100	M80x2	80	M90x3	120	85	258	175	58	G1 1/4	M42x2	186	219	126	35	705	-	670
160	110	M100x2	100	M100x3	140	95	292	200	65	G1 1/2	M48x2	210	240	142.5	40	785	-	980
180	125	M110x2	110	M110x4	150	110	325	220	65	G1 1/2	M48x2	241	264	159.5	45	838	-	1120
200	140	M120x3	120	M120x4	160	120	350	245	65	G1 1/2	M48x2	262	278	172.5	45	888	-	1700
220	160	M120x3	120	M120x4	160	140	375	292	65	G1 1/2	M48x2	262	326	185	40	970	-	1700
250	180	M130x3	130	M150x4	190	160	440	324	65	G1 1/2	M48x2	272	336	218	40	1055	20	2900
280	200	-	-	M160x4	200	180	460	368	65	G1 1/2	M48x2	282	366	228	40	1115	-	-
320	220	-	-	M180x4	220	200	490	406	65	G1 1/2	M48x2	287	391	243	40	1195	340	-

ØAL	ØMM	F <sub>adm</sub> <sup>19)</sup> kN	X* max	LT	M1	MS	ØCX	EP -0.4	EX	Z	ØRA	VE	L2	L7	L8	H 13)	H 14)	B
40	28	38.2	1000	35	34	36	30 <sub>-0.010</sub>	28	22 <sub>-0.12</sub>	6°	52	45	102	200	83	108	115	64
50	36	55.1	1000	45	40	42	35 <sub>-0.012</sub>	30	25 <sub>-0.12</sub>	6°	70	47	115	200	102	116	125	64
63	45	90.0	2000	50	50	52	40 <sub>-0.012</sub>	35	28 <sub>-0.12</sub>	7°	88	43	127	200	104	133	140	64
80	56	131.4	2000	55	62.5	65	50 <sub>-0.012</sub>	40	35 <sub>-0.12</sub>	6°	98	53	137	200	109	137	125	64
100	70	144.0	3000	65	70	70	60 <sub>-0.015</sub>	50	44 <sub>-0.15</sub>	6°	120	55	155	200	127	156	135	64
125	90	194.4	3000	75	82	82	70 <sub>-0.015</sub>	55	49 <sub>-0.15</sub>	6°	150	68	185	200	161	181	150	64
140	100	241.2	3000	80	95	95	80 <sub>-0.015</sub>	60	55 <sub>-0.15</sub>	6°	170	75	192	200	166	192	160	64
160	110	352.8	3000	90	113	113	90 <sub>-0.020</sub>	65	60 <sub>-0.20</sub>	5°	200	90	225	200	193	210	170	64
180	125	403.2	3000	105	125	125	100 <sub>-0.020</sub>	70	70 <sub>-0.20</sub>	7°	230	100	235	200	202	226	180	64
200	140	612.0	3000	115	142.5	142.5	110 <sub>-0.020</sub>	80	70 <sub>-0.20</sub>	6°	250	110	245	200	214	239	195	64
220	160	612.0	3000	115	150 <sup>12)</sup>	140 <sup>12)</sup>	110 <sub>-0.020</sub>	80	70 <sub>-0.20</sub>	6°	275	125	270	200	238	254	215	64
250	180	1044.0	3000	140	188 <sup>12)</sup>	178 <sup>12)</sup>	120 <sub>-0.020</sub>	90	85 <sub>-0.20</sub>	6°	320	135	320	200	283	284	235	64
280	200	-	3000	170	210 <sup>12)</sup>	200 <sup>12)</sup>	140 <sub>-0.025</sub>	100	90 <sub>-0.25</sub>	7°	335	150	350	200	315	294	285	64
320	220	-	3000	200	260 <sup>12)</sup>	250 <sup>12)</sup>	160 <sub>-0.025</sub>	110	105 <sub>-0.25</sub>	8°	350	165	400	200	400	309	300	64

ØAL = Piston Ø

ØMM = Piston rod Ø

X\* = Stroke length

X\*max = Max. stroke length

X\*min = Min. stroke length

With hydraulic cylinders with end position cushioning, observe the notice on page 59!

1) Bleeding: With view to the piston rod, the position is offset by 90° in relation to the line connection (clockwise)

2) Ø D4 max. 0.5 mm deep

3) Throttle valve only with end position cushioning "E" (180° for bleeding)

4) Flange connections see separate table pages 36 and 37

5) Thread design "G"

6) Thread design "A"

9) Observe the min. stroke length "X\*min"

10) Related bolt Ø m6;

Related bolt Ø j6 for maintenance-free spherical bearing

11) Standard version "W" Lubricating nipple, cone head form A according to DIN 71412; not applicable to spherical bearing, maintenance-free "A"

12) The specified dimensions are maximum values, tolerance classes 342 according to ISO 9013 Thermal cutting

13) Dimensions for position transducer output "N" and "P"

14) Dimensions for position transducer output "C", "F" and "D"

16) Line connection "B" and "C"

17) Line connection "M"

18) C<sub>0</sub> = Static load rating of the swivel head

19) F<sub>adm</sub> = Max. admissible load of the swivel head for increasing or alternating loads

## Round flange at head CSH3: MF3

CSH3 MF3

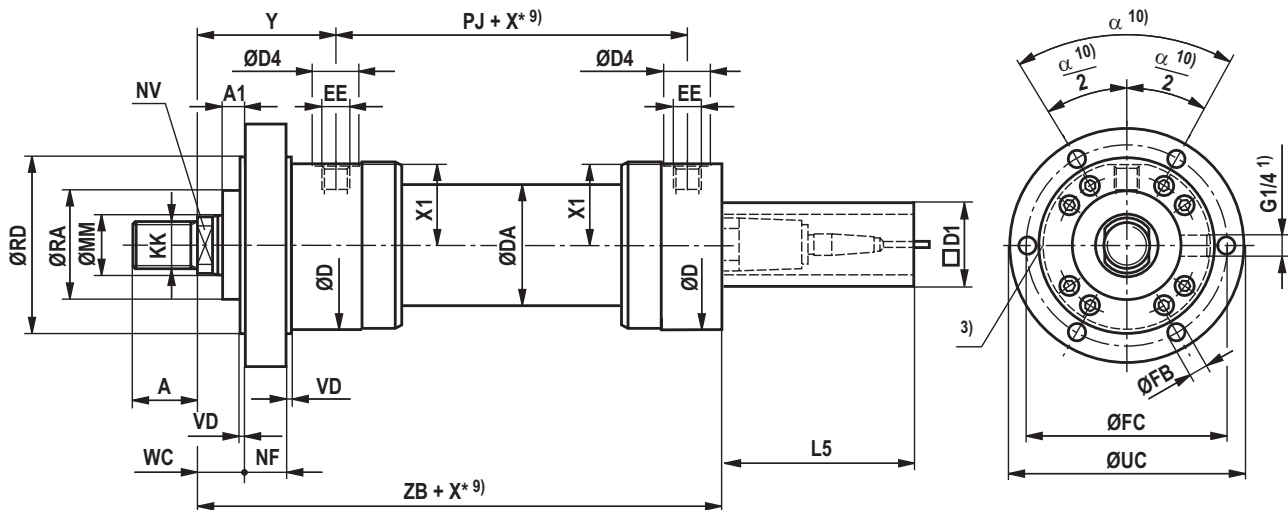

## Dimensions CSH3: MF3 (dimensions in mm)

ØAL	ØMM	KK 5)	A 5)	KK 6)	A 6)	NV	ØD	ØDA	ØD4 2)	EE 4; 16)	EE 4; 17)	Y	PJ	X1	ØRD e8
40	28	M22x1.5	22	M24x2	35	22	92	52	34	G1/2	M22x1.5	91	120	43	95
50	36	M28x1.5	28	M30x2	45	30	108	62	34	G1/2	M22x1.5	90	120	51.5	115
63	45	M35x1.5	35	M39x3	55	36	140	78	42	G3/4	M27x2	117	133	67	150
80	56	M45x1.5	45	M50x3	75	46	148	100	42	G3/4	M27x2	124	146	71.5	160
100	70	M58x1.5	58	M64x3	95	60	186	125	47	G1	M33x2	119	171	90.5	200
125	90	M65x1.5	65	M80x3	110	75	235	160	58	G1 1/4	M42x2	170	205	114	245
140	100	M80x2	80	M90x3	120	85	258	175	58	G1 1/4	M42x2	186	219	126	280
160	110	M100x2	100	M100x3	140	95	292	200	65	G1 1/2	M48x2	210	240	142.5	300
180	125	M110x2	110	M110x4	150	110	325	220	65	G1 1/2	M48x2	241	264	159.5	335
200	140	M120x3	120	M120x4	160	120	350	245	65	G1 1/2	M48x2	262	278	172.5	360
220	160	M120x3	120	M120x4	160	140	375	292	65	G1 1/2	M48x2	262	326	185	400
250	180	M130x3	130	M150x4	190	160	440	324	65	G1 1/2	M48x2	272	336	218	450
280	200	-	-	M160x4	200	180	460	368	65	G1 1/2	M48x2	282	366	228	470
320	220	-	-	M180x4	220	200	490	406	65	G1 1/2	M48x2	287	391	243	510

ØAL	ØMM	WC	VD	X* max	L5	D1 max	NF	A1	ZB	X* min	ØFB H13	ØFC js13	ØUC -1	α	ØRA
40	28	23	5	1000	166	80	35	0	247	-	13.5	120	145	60°	52
50	36	20	5	1000	166	96	40	0	246	-	13.5	140	165	60°	70
63	45	20	5	2000	166	96	40	0	304	-	17.5	180	210	60°	88
80	56	20	5	2000	166	96	50	0	332	-	17.5	195	230	60°	98
100	70	20	5	3000	166	96	55	0	347	-	22	230	270	60°	120
125	90	25	5	3000	166	96	70	0	427	-	26	290	335	60°	150
140	100	30	10	3000	166	96	70	0	460	-	30	330	380	60°	170
160	110	40	10	3000	166	96	80	0	515	-	30	360	420	45°	200
180	125	40	10	3000	166	96	95	0	565	-	36	400	470	45°	230
200	140	40	10	3000	166	96	105	0	600	-	36	430	500	45°	250
220	160	40	10	3000	166	96	115	0	655	-	39	475	550	45°	275
250	180	40	10	3000	166	96	125	0	695	20	45	530	610	45°	320
280	200	50	10	3000	166	96	130	0	735	-	45	550	630	45°	335
320	220	55	10	3000	166	96	140	5	775	340	45	590	670	30°	350

ØAL = Piston Ø

ØMM = Piston rod Ø

X\* = Stroke length

X\*max = Max. stroke length

X\*min = Min. stroke length

With hydraulic cylinders with end position cushioning, observe the notice on page 59!

1) Bleeding: With view to the piston rod, the position is offset by 90° in relation to the line connection (clockwise)

2) Ø D4 max. 0.5 mm deep

3) Throttle valve only with end position cushioning "E" (180° for bleeding)

4) Flange connections see separate table pages 36 and 37

5) Thread design "G"

6) Thread design "A"

9) Observe the min. stroke length "X\*min"

10) With piston Ø 160 to 280 mm 8 mounting bores  
With piston Ø 320 mm 12 mounting bores

16) Line connection "B" and "C"

17) Line connection "M"

### Round flange at base CSH3: MF4

CSH3 MF4; ØAL 40 to 100 mm

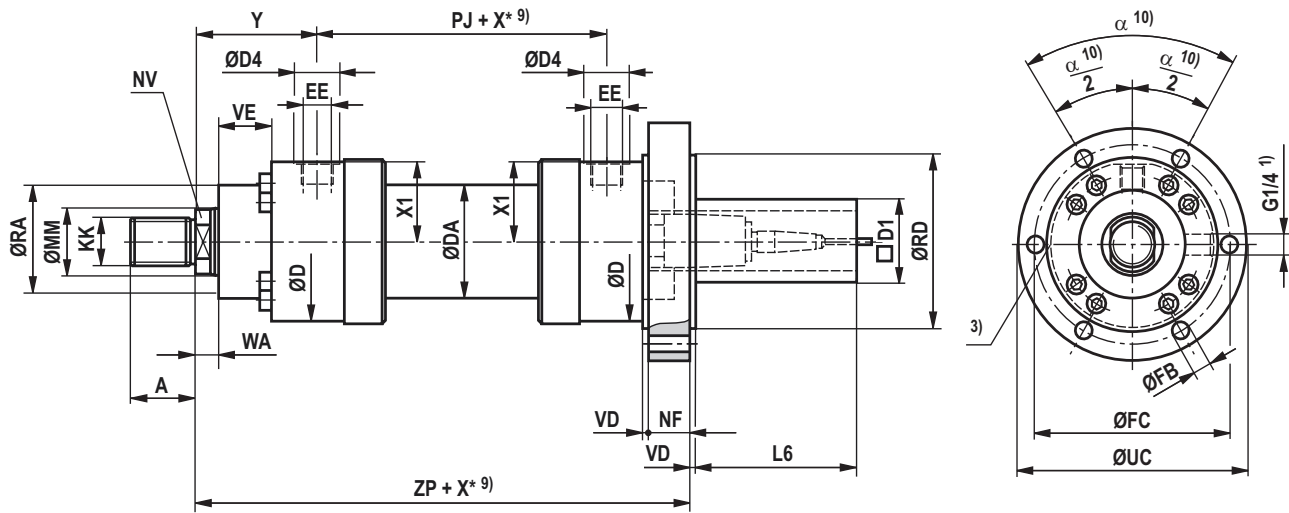

CSH3 MF4; ØAL 125 to 320 mm

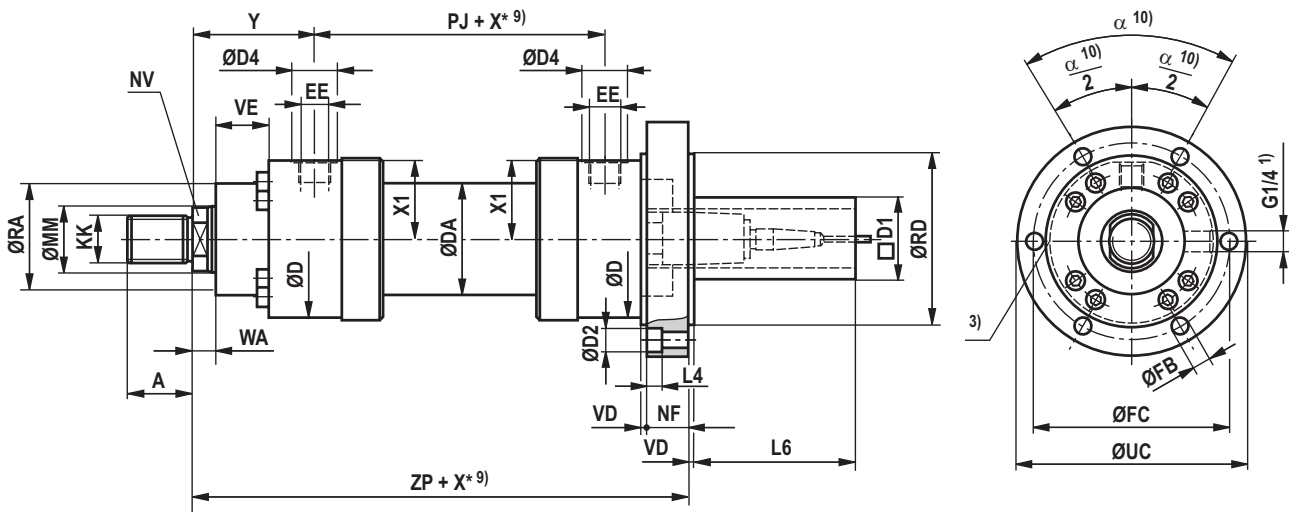

## Dimensions CSH3: MF4 (dimensions in mm)

ØAL	ØMM	KK 5)	A 5)	KK 6)	A 6)	NV	ØD	ØDA	ØD4 2)	EE 4; 16)	EE 4; 17)	Y	PJ	X1	D1 max	ØD2	WA
40	28	M22x1.5	22	M24x2	35	22	92	52	34	G1/2	M22x1.5	91	120	43	80	0	18
50	36	M28x1.5	28	M30x2	45	30	108	62	34	G1/2	M22x1.5	90	120	51.5	96	0	18
63	45	M35x1.5	35	M39x3	55	36	140	78	42	G3/4	M27x2	117	133	67	96	0	22
80	56	M45x1.5	45	M50x3	75	46	148	100	42	G3/4	M27x2	124	146	71.5	96	0	22
100	70	M58x1.5	58	M64x3	95	60	186	125	47	G1	M33x2	119	171	90.5	96	0	25
125	90	M65x1.5	65	M80x3	110	75	235	160	58	G1 1/4	M42x2	170	205	114	96	40	32
140	100	M80x2	80	M90x3	120	85	258	175	58	G1 1/4	M42x2	186	219	126	96	43	35
160	110	M100x2	100	M100x3	140	95	292	200	65	G1 1/2	M48x2	210	240	142.5	96	43	40
180	125	M110x2	110	M110x4	150	110	325	220	65	G1 1/2	M48x2	241	264	159.5	96	53	45
200	140	M120x3	120	M120x4	160	120	350	245	65	G1 1/2	M48x2	262	278	172.5	96	53	45
220	160	M120x3	120	M120x4	160	140	375	292	65	G1 1/2	M48x2	262	326	185	96	57	40
250	180	M130x3	130	M150x4	190	160	440	324	65	G1 1/2	M48x2	272	336	218	96	66	40
280	200	–	–	M160x4	200	180	460	368	65	G1 1/2	M48x2	282	366	228	96	66	40
320	220	–	–	M180x4	220	200	490	406	65	G1 1/2	M48x2	287	391	243	96	66	40

ØAL	ØMM	X* max	L4	L6	ZP	X* min	NF	VD	ØRD e8	ØFB H13	ØFC js13	ØUC -1	α	ØRA	VE
40	28	1000	0	166	282	–	35	5	95	13.5	120	145	60°	52	45
50	36	1000	0	166	285	–	40	5	115	13.5	140	165	60°	70	47
63	45	2000	0	153	340	–	40	5	150	17.5	180	210	60°	88	43
80	56	2000	0	123	370	–	50	5	160	17.5	195	230	60°	98	53
100	70	3000	0	106	402	–	55	5	200	22	230	270	60°	120	55
125	90	3000	25.5	93	495	–	70	5	245	26	290	335	60°	150	68
140	100	3000	28.5	84	532	–	70	10	280	30	330	380	60°	170	75
160	110	3000	28.5	71	600	–	80	10	300	30	360	420	45°	200	90
180	125	3000	35	56	665	–	95	10	335	36	400	470	45°	230	100
200	140	3000	35	46	710	–	105	10	360	36	430	500	45°	250	110
220	160	3000	38	41	770	–	115	10	400	39	475	550	45°	275	125
250	180	3000	44	31	820	20	125	10	450	45	530	610	45°	320	135
280	200	3000	44	26	865	–	130	10	470	45	550	630	45°	335	150
320	220	3000	44	16	915	340	140	10	510	45	590	670	30°	350	165

ØAL = Piston Ø

ØMM = Piston rod Ø

X\* = Stroke length

X\*max = Max. stroke length

X\*min = Min. stroke length

With hydraulic cylinders with end position cushioning, observe the notice on page 59!

1) Bleeding: With view to the piston rod, the position is offset by 90° in relation to the line connection (clockwise)

2) Ø D4 max. 0.5 mm deep

3) Throttle valve only with end position cushioning "E" (180° for bleeding)

4) Flange connections see separate table pages 36 and 37

5) Thread design "G"

6) Thread design "A"

9) Observe the min. stroke length "X\*min"

10) With piston Ø 160 to 280 mm 8 mounting bores  
With piston Ø 320 mm 12 mounting bores

16) Line connection "B" and "C"

17) Line connection "M"

# Trunnion CSH3: MT4

## CSH3 MT4

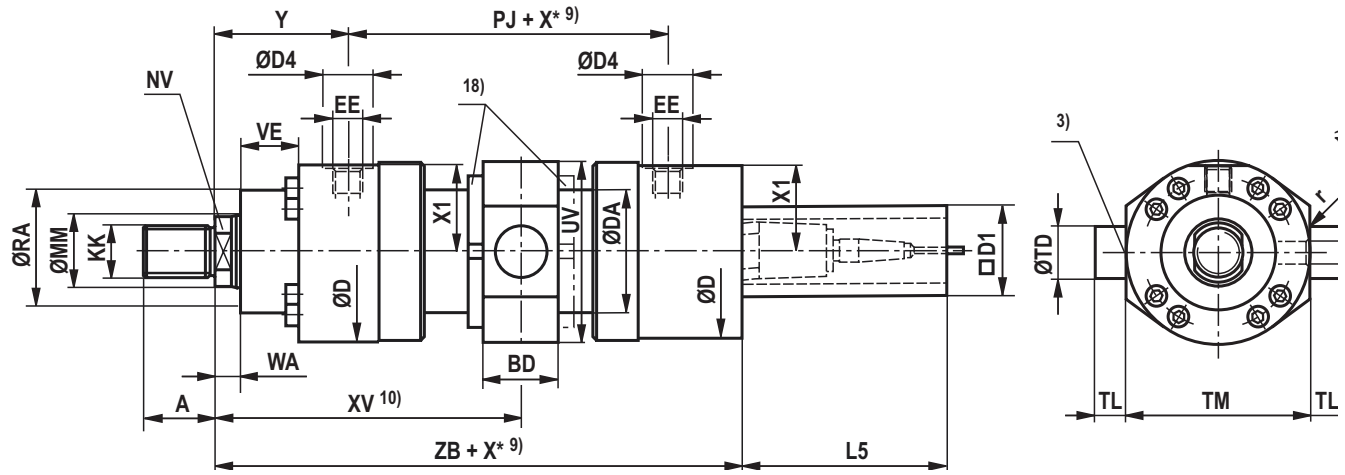

Dimensions for cylinder with piston rod extension "LY" in retracted condition

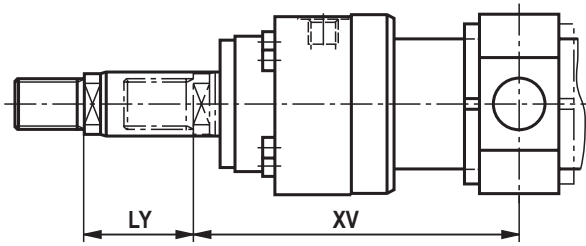



## Dimensions CSH3: MT4 (dimensions in mm)

ØAL	ØMM	KK 5)	A 5)	KK 6)	A 6)	NV	ØD	ØDA	ØD4 2)	EE 4; 16)	EE 4; 17)	Y	PJ	X1	WA	ZB
40	28	M22x1.5	22	M24x2	35	22	92	52	34	G1/2	M22x1.5	91	120	43	18	247
50	36	M28x1.5	28	M30x2	45	30	108	62	34	G1/2	M22x1.5	90	120	51.5	18	246
63	45	M35x1.5	35	M39x3	55	36	140	78	42	G3/4	M27x2	117	133	67	22	304
80	56	M45x1.5	45	M50x3	75	46	148	100	42	G3/4	M27x2	124	146	71.5	22	332
100	70	M58x1.5	58	M64x3	95	60	186	125	47	G1	M33x2	119	171	90.5	25	347
125	90	M65x1.5	65	M80x3	110	75	235	160	58	G1 1/4	M42x2	170	205	114	32	427
140	100	M80x2	80	M90x3	120	85	258	175	58	G1 1/4	M42x2	186	219	126	35	460
160	110	M100x2	100	M100x3	140	95	292	200	65	G1 1/2	M48x2	210	240	142.5	40	515
180	125	M110x2	110	M110x4	150	110	325	220	65	G1 1/2	M48x2	241	264	159.5	45	565
200	140	M120x3	120	M120x4	160	120	350	245	65	G1 1/2	M48x2	262	278	172.5	45	600
220	160	M120x3	120	M120x4	160	140	375	292	65	G1 1/2	M48x2	262	326	185	40	655
250	180	M130x3	130	M150x4	190	160	440	324	65	G1 1/2	M48x2	272	336	218	40	695
280	200	–	–	M160x4	200	180	460	368	65	G1 1/2	M48x2	282	366	228	40	735
320	220	–	–	M180x4	220	200	490	406	65	G1 1/2	M48x2	287	391	243	40	775

ØAL	ØMM	X* max	L5	D1 max	X* min	XV 11) cent	XV min	XV max	BD	UV 12)	ØTD e8	TL js16	TM h12	r	ØRA	VE
40	28	1000	166	80	42	151+X*/2	172	138+X*	48	101	40	30	95	2	52	45
50	36	1000	166	96	50	150+X*/2	175	134+X*	48	117	40	30	120	2	70	47
63	45	2000	166	96	64	183.5+X*/2	215.5	163.5+X*	53	153	45	35	150	2	88	43
80	56	2000	166	96	82	197+X*/2	238	168+X*	68	169	55	50	160	2	98	53
100	70	3000	166	96	109	204.5+X*/2	259	165+X*	88	203	60	55	200	2	120	55
125	90	3000	166	96	131	272.5+X*/2	338	207+X*	118	252	75	60	245	2.5	150	68
140	100	3000	166	96	147	295.5+X*/2	369	222+X*	128	282	85	70	280	2.5	170	75
160	110	3000	166	96	186	330+X*/2	423	237+X*	148	310	95	80	300	2.5	200	90
180	125	3000	166	96	212	373+X*/2	479	267+X*	168	348	110	90	335	2.5	230	100
200	140	3000	166	96	228	401+X*/2	515	287+X*	188	373	120	100	360	2.5	250	110
220	160	3000	166	96	205	425+X*/2	527.5	322.5+X*	165	398	130	100	400	2.5	275	125
250	180	3000	166	96	245	440+X*/2	562.5	317.5+X*	175	463	140	100	450	5	320	135
280	200	3000	166	96	245	465+X*/2	587.5	342.5+X*	205	486	170	125	480	5	335	150
320	220	3000	166	96	600	482.5+X*/2	782.5	182.5+X*	245	537	200	150	500	5	350	165

ØAL = Piston Ø

ØMM = Piston rod Ø

X\* = Stroke length

X\*max = Max. stroke length

X\*min = Min. stroke length

With hydraulic cylinders with end position cushioning, observe the notice on page 59!

1) Bleeding: With view to the piston rod, the position is offset by 90° in relation to the line connection (clockwise)

2) Ø D4 max. 0.5 mm deep

3) Throttle valve only with end position cushioning "E" (180° for bleeding)

4) Flange connections see separate table pages 36 and 37

5) Thread design "G"

6) Thread design "A"

9) Observe the min. stroke length "X\*min"

10) When ordering, always specify the "XV" dimension in the plain text. Preferred XV dimension: Observe the trunnion position in the cylinder center XVmin and XVmax

11) XVcent recommendation: Trunnion position in cylinder center

12) The specified dimensions are maximum values, tolerance classes 342 according to ISO 9013 Thermal cutting

16) Line connection "B" and "C"

17) Line connection "M"

18) Trunnion nut with ØAL ≥ 125 mm either at head or at base side depending on the position of the trunnion (XV)

**Important installation information:** During installation, it must be ensured that the trunnion bearings are installed up to the trunnion shoulders. Any variation may reduce the product's service life.

## Foot mounting CSH3: MS2

CSH3 MS2; ØAL 40 to 320 mm

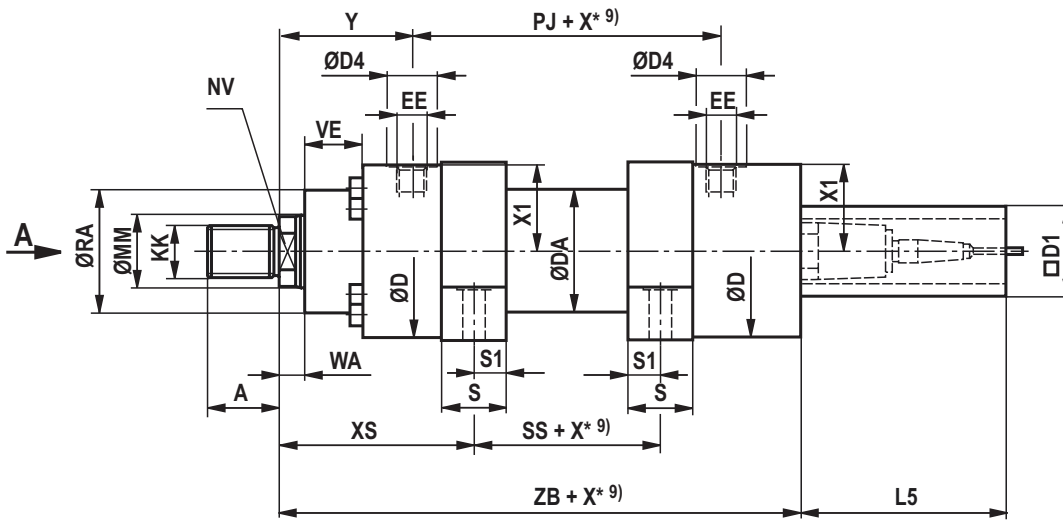

View A

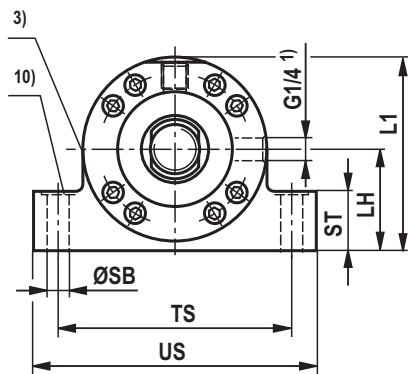

## Dimensions CSH3: MS2 (dimensions in mm)

ØAL	ØMM	KK 5)	A 5)	KK 6)	A 6)	NV	ØD	ØDA	ØD4 2)	EE 4; 16)	EE 4; 17)	Y	PJ	X1	WA	XS
40	28	M22x1.5	22	M24x2	35	22	92	52	34	G1/2	M22x1.5	91	120	43	18	126
50	36	M28x1.5	28	M30x2	45	30	108	62	34	G1/2	M22x1.5	90	120	51.5	18	130
63	45	M35x1.5	35	M39x3	55	36	140	78	42	G3/4	M27x2	117	133	67	22	164
80	56	M45x1.5	45	M50x3	75	46	148	100	42	G3/4	M27x2	124	146	71.5	22	176
100	70	M58x1.5	58	M64x3	95	60	186	125	47	G1	M33x2	119	171	90.5	25	179
125	90	M65x1.5	65	M80x3	110	75	235	160	58	G1 1/4	M42x2	170	205	114	32	245
140	100	M80x2	80	M90x3	120	85	258	175	58	G1 1/4	M42x2	186	219	126	35	265.5
160	110	M100x2	100	M100x3	140	95	292	200	65	G1 1/2	M48x2	210	240	142.5	40	302.5
180	125	M110x2	110	M110x4	150	110	325	220	65	G1 1/2	M48x2	241	264	159.5	45	353.5
200	140	M120x3	120	M120x4	160	120	350	245	65	G1 1/2	M48x2	262	278	172.5	45	379.5
220	160	M120x3	120	M120x4	160	140	375	292	65	G1 1/2	M48x2	262	326	185	40	387.5
250	180	M130x3	130	M150x4	190	160	440	324	65	G1 1/2	M48x2	272	336	218	40	397.5
280	200	-	-	M160x4	200	180	460	368	65	G1 1/2	M48x2	282	366	228	40	410
320	220	-	-	M180x4	220	200	490	406	65	G1 1/2	M48x2	287	391	243	40	440

ØAL	ØMM	X* max	L5	D1 max	ZB	SS	X* min	S	S1	ØSB H13	ST	TS js13	US 12)	LH	L1 12)	ØRA	VE
40	28	1000	166	80	247	50	-	30	15	17.5	32	125	164	50	100	52	45
50	36	1000	166	96	246	40	4	40	20	22	37	150	197	60	118	70	47
63	45	2000	166	96	304	39	15	50	25	24	47	185	235	75	149	88	43
80	56	2000	166	96	332	42	22	60	30	26	52	210	270	80	160	98	53
100	70	3000	166	96	347	51	23	70	35	33	62	250	320	100	200	120	55
125	90	3000	166	96	427	55	39	90	45	40	72	310	392	120	245	150	68
140	100	3000	166	96	460	60	39	95	47.5	40	77	340	422	135	271	170	75
160	110	3000	166	96	515	55	64	115	57.5	45	87	370	462	150	305	200	90
180	125	3000	166	96	565	39	110	145	72.5	45	79	415	515	165	337	230	100
200	140	3000	166	96	600	43	116	155	77.5	52	112	460	570	180	366	250	110
220	160	3000	166	96	655	75	100	155	77.5	52	112	500	610	200	398	275	125
250	180	3000	166	96	695	85	90	155	77.5	52	122	550	660	225	456	320	135
280	200	3000	166	96	735	110	70	160	80	62	142	600	722	235	476	335	150
320	220	3000	166	96	775	85	400	190	95	74	162	650	785	255	512	350	165

ØAL = Piston Ø

ØMM = Piston rod Ø

X\* = Stroke length

X\*max = Max. stroke length

X\*min = Min. stroke length

With hydraulic cylinders with end position cushioning, observe the notice on page 59!

1) Bleeding: With view to the piston rod, the position is offset by 90° in relation to the line connection (clockwise)

2) Ø D4 max. 0.5 mm deep

3) Throttle valve only with end position cushioning "E" (180° for bleeding)

4) Flange connections see separate table pages 36 and 37

5) Thread design "G"

6) Thread design "A"

9) Observe the min. stroke length "X\*min"

10) Recess 2 mm deep, for hexagon socket head cap screws; ISO 4762 (for piston Ø 320 mm DIN 931) – The screws must not be subjected to shear force. Force distribution via additional external fitting strip.

12) The specified dimensions are maximum values, tolerance classes 342 according to ISO 9013 Thermal cutting

16) Line connection "B" and "C"

17) Line connection "M"

## Flange ports

CDH3 / CSH3

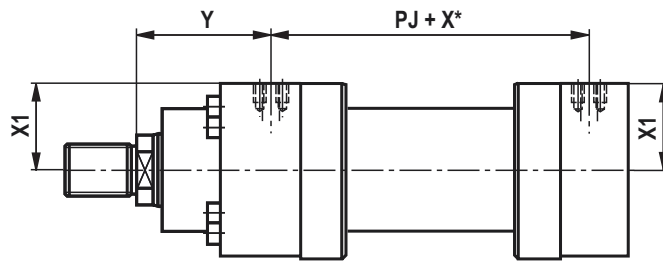

CGH3

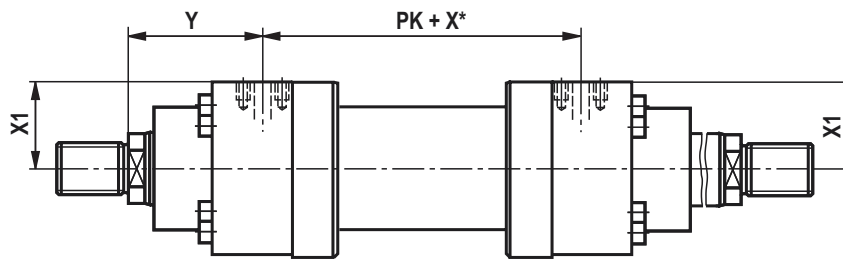

Porting pattern for rectangular flange according to ISO 6162-2 tab. 2 type 1

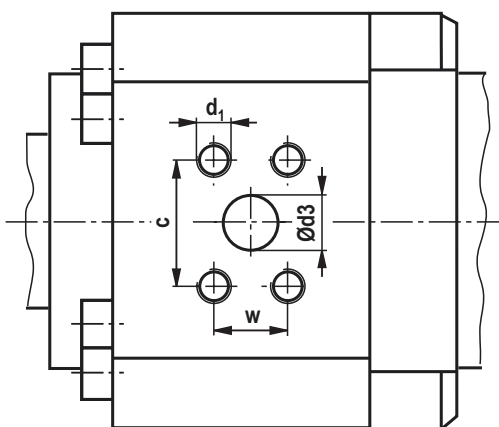

Porting pattern for square flange according to ISO 6164 table 2

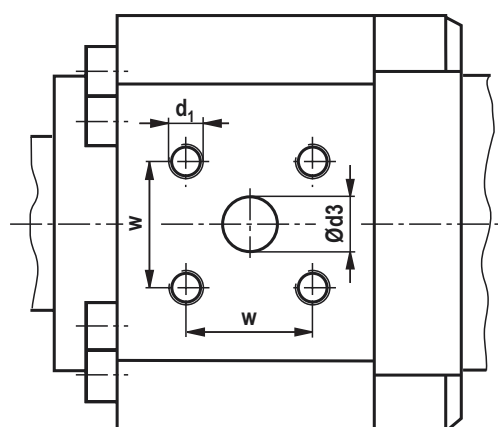

## Flange ports

Dimensions (Dimensions in mm)

ØAL	Version "D" ISO 6162-2 tab. 2 type 1 (400 bar) (≙ SAE 6000 PSI)										Version "H" ISO 6164 tab. 2 (400 bar)							
	Y	PJ PK	X1	Ød <sub>3</sub>	Ød <sub>3</sub> <sup>3)</sup>	c ±0.25	w ±0.25	d <sub>1</sub>	t <sub>1</sub> <sup>1)</sup>	p <sup>2)</sup>	Y	PJ PK	X1	Ød <sub>3</sub>	w ±0.25	d <sub>1</sub>	t <sub>1</sub> <sup>1)</sup>	p <sup>2)</sup>
40	-	-	-	-	-	-	-	-	-	-	90	122	42.5	10	24.7	M6	12.5	400
50	-	-	-	-	-	-	-	-	-	-	89	122	51	10	24.7	M6	12.5	400
63	113	141	65	13	1/2"	40.5	18.2	M8	16	400	113	141	66	19	35.4	M8	16	400
80	120	154	69	13	1/2"	40.5	18.2	M8	16	400	120	154	70	19	35.4	M8	16	400
100	114	181	87	19	3/4"	50.8	23.8	M10	20	400	118	173	89.5	19	35.4	M8	16	400
125	162.5	220	111.5	25	1"	57.2	27.8	M12	24	400	162.5	220	112.5	32	51.6	M12	24	400
140	179.5	232	121.5	32	1 1/4"	66.6	31.8	M14	26	400	179.5	232	124.5	32	51.6	M12	24	400
160	197.5	265	139.5	32	1 1/4"	66.6	31.8	M14	26	400	197.5	265	140.5	38	60.1	M16	30	400
180	233.5	279	156.5	32	1 1/4"	66.6	31.8	M14	26	400	233.5	279	156.5	38	60.1	M16	30	400
200	254.5	293	167.5	38	1 1/2"	79.3	36.5	M16	30	400	254.5	293	170.5	38	60.1	M16	30	400
220	262	326	178	38	1 1/2"	79.3	36.5	M16	30	400	262	326	182	38	60.1	M16	30	400
250	272	336	212	38	1 1/2"	79.3	36.5	M16	30	400	272	336	216	38	60.1	M16	30	400
280	282	366	222	38	1 1/2"	79.3	36.5	M16	30	400	282	366	226	38	60.1	M16	30	400
320	287	391	236	51	2"	96.8	44.5	M20	36	400	287	391	240	51	69.3	M16	30	400

Main dimensions see pages 10 to 21 and/or pages 24 to 35

ØAL = Piston Ø

X\* = Stroke length

1) Thread depth

2) Max. operating pressure for related flanges in bar

3) Flange porting pattern according to ISO 6162-2 tab. 2  
type 1 corresponds to flange porting pattern according to  
SAE 6000 PSI

## Subplates for valve mounting (SL and SV valve)

**Note:**

Valves, fittings and piping are **not** included in the scope of delivery!

- 1 Port B to the piston side according to ISO 6164
- 2 Bore for locking pin
- 3 Adapter plate for type of mounting MT4 (included in the scope of delivery for MT4)
- 4 Line connection "B" dimensions "EE" see also pages 10 to 21 and pages 24 to 35

**Important notice**

Subplates for SL and SV valves (isolator valves)

**Note:**

Seal designs T, G, L, R, S and V are not designed for the static holding function!

**Installation situation with MT4**

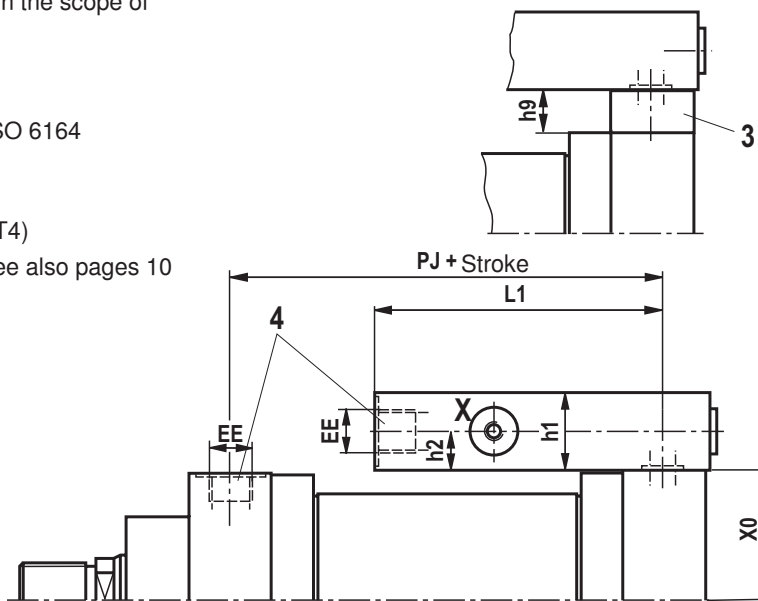

**NG6**

Porting pattern according to ISO 24340 form A and ISO 4401

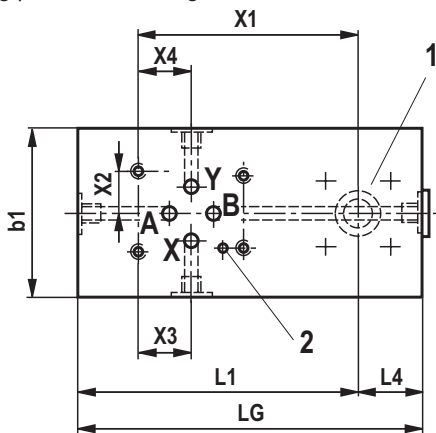

**NG10 and 20**

Porting pattern according to ISO 5781

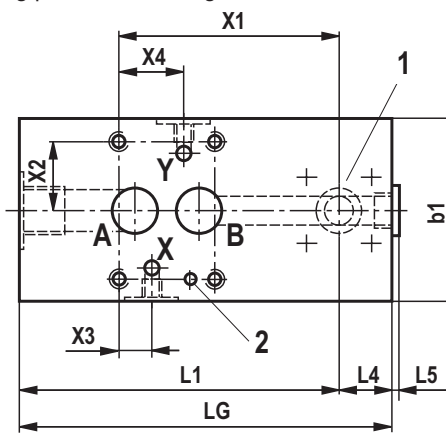

**NG30**

Porting pattern according to ISO 5781

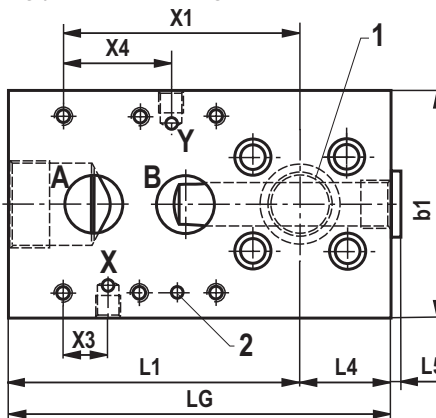

## Subplates for valve mounting (SL and SV valve – dimensions in mm)

ØAL	Valve size	PJ	EE	Stroke min <sup>1)</sup>		X0	Plate dimensions							Port size, porting pattern						Position point valve	
				2)	3)		L1	L4	L5	LG	b1	h1	h9	h2	A	X	Y	X3	X4	X1	X2
				40	6		121	G1/2	50	50	42.5	90	20	4	110	55	40	10	20	G1/2	G1/4
50	6	121	G1/2	50	50	51.0	90	20	4	110	55	40	10	20	G1/2	G1/4	G1/4	21.5	21.5	65.5	15.5
63	6	137	G3/4	64	64	66.0	105	30	5	135	60	45	20	22.5	G3/4	G1/4	G1/4	21.5	21.5	75.5	15.5
	10	137	G3/4	64	64	66.0	110	30	5	140	85	45	20	22.5	G3/4	G1/4	G1/4	21.4	21.4	78	33.3
80	6	150	G3/4	58	82	70.0	105	30	5	135	60	45	20	22.5	G3/4	G1/4	G1/4	21.5	21.5	75.5	15.5
	10	150	G3/4	58	82	70.0	110	30	5	140	85	45	20	22.5	G3/4	G1/4	G1/4	21.4	21.4	78	33.3
100	10	172	G1	50	109	89.5	102	28	5	130	85	50	20	25	G1	G1/4	G1/4	21.4	21.4	70	33.3
125	10	212.5	G1 1/4	80	131	112.5	120	40	5	160	85	60	30	30	G1 1/4	G1/4	G1/4	21.4	21.4	90	33.3
	20	212.5	G1 1/4	80	131	112.5	135	50	5	185	100	60	30	30	G1 1/4	G1/4	G1/4	20.8	39.7	105	39.7
	30	212.5	G1 1/4	80	131	112.5	160	50	5	210	125	60	30	30	G1 1/4	G1/4	G1/4	24.6	59.6	130	48.4
140	10	225.5	G1 1/4	60	147	124.5	120	40	5	160	85	60	30	30	G1 1/4	G1/4	G1/4	21.4	21.4	90	33.3
	20	225.5	G1 1/4	60	147	124.5	135	50	5	185	100	60	30	30	G1 1/4	G1/4	G1/4	20.8	39.7	105	39.7
	30	225.5	G1 1/4	60	147	124.5	160	50	5	210	125	60	30	30	G1 1/4	G1/4	G1/4	24.6	59.6	130	48.4
160	10	252.5	G1 1/2	60 <sup>4)</sup>	186	140.5	130	45	5	175	95	70	20	35	G1 1/2	G1/4	G1/4	21.4	21.4	100	33.3
	20	252.5	G1 1/2	60 <sup>4)</sup>	186	140.5	140	45	5	185	100	70	20	35	G1 1/2	G1/4	G1/4	20.8	39.7	115	39.7
	30	252.5	G1 1/2	60 <sup>4)</sup>	186	140.5	165	45	5	210	125	70	20	35	G1 1/2	G1/4	G1/4	24.6	59.6	140	48.4
180	10	271.5	G1 1/2	50 <sup>4)</sup>	212	156.5	130	45	5	175	95	70	20	35	G1 1/2	G1/4	G1/4	21.4	21.4	100	33.3
	20	271.5	G1 1/2	50 <sup>4)</sup>	212	156.5	140	45	5	185	100	70	20	35	G1 1/2	G1/4	G1/4	20.8	39.7	115	39.7
	30	271.5	G1 1/2	50 <sup>4)</sup>	212	156.5	165	45	5	210	125	70	20	35	G1 1/2	G1/4	G1/4	24.6	59.6	140	48.4
200	10	285.5	G1 1/2	30 <sup>4)</sup>	228	170.5	130	45	5	175	95	70	20	35	G1 1/2	G1/4	G1/4	21.4	21.4	100	33.3
	20	285.5	G1 1/2	30 <sup>4)</sup>	228	170.5	140	45	5	185	100	70	20	35	G1 1/2	G1/4	G1/4	20.8	39.7	115	39.7
	30	285.5	G1 1/2	30 <sup>4)</sup>	228	170.5	165	45	5	210	125	70	20	35	G1 1/2	G1/4	G1/4	24.6	59.6	140	48.4

ØAL = Piston Ø

<sup>1)</sup> The information only applies to the following connection situation!

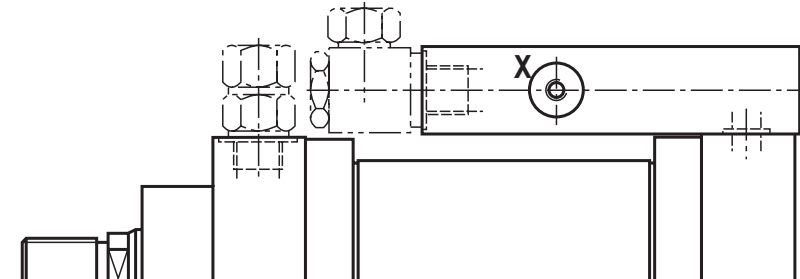

<sup>2)</sup> Not for MT4

<sup>3)</sup> Only for MT4

<sup>4)</sup> With type of mounting "MS2", observe X\*min on page 21 and/or 35





## Subplates for valve mounting (directional and high-response valves – dimensions in mm)

ØAL	Valve size	PJ	EE	Stroke min	Plate dimensions																
					L1	L4	L5 <sub>max</sub>	H1	H2 <sup>1)</sup>	H2 <sup>2)</sup>	SW1	ØRa	b1	h1	LG	HG <sup>1)</sup>	HG <sup>2)</sup>	b2	X0	h7	h9
40	6	121	G1/2	242	90	20	4	98.0	62.5	72.5	30	16.0x2.5	65	40	110	82.5	92.5	32.5	42.5	20	10
50	6	121	G1/2	242	90	20	4	106.5	71.0	81.0	30	16.0x2.5	65	40	110	91.0	101.0	32.5	51.0	20	10
63	6	137	G3/4	278	105	30	5	132.0	88.5	108.5	36	20.0x3.0	75	45	135	111.0	131.0	37.5	66.0	22.5	20
	10	137	G3/4	303	130	30	5	132.0	89.0	109.0	36	20.0x3.0	90	70	160	136.0	156.0	45	66.0	23	20
80	6	150	G3/4	265	105	30	5	136.5	92.5	112.5	36	20.0x3.0	75	45	135	115.0	135.0	37.5	70.0	22.5	20
	10	150	G3/4	290	130	30	5	136.5	93.0	113.0	36	20.0x3.0	90	70	160	140.0	160.0	45	70.0	23	20
100	10	172	G1	317	132	28	5	163.5	119.5	139.5	46	25.0x4.0	90	80	160	169.5	189.5	45	89.5	30	20
125	10	212.5	G1 1/4	341	150	40	5	192.5	147.5	177.5	50	30.0x5.0	105	95	190	207.5	237.5	52.5	112.5	35	30
	16	212.5	G1 1/4	371	180	40	5	192.5	162.5	192.5	50	30.0x5.0	125	105	220	217.5	247.5	62.5	112.5	50	30
	25	212.5	G1 1/4	391	200	50	0	192.5	167.5	197.5	50	30.0x5.0	155	110	250	222.5	252.5	77.5	112.5	55	30
140	10	225.5	G1 1/4	328	150	40	5	204.5	159.5	189.5	50	30.0x5.0	105	95	190	219.5	249.5	52.5	124.5	35	30
	16	225.5	G1 1/4	358	180	40	5	204.5	174.5	204.5	50	30.0x5.0	125	105	220	229.5	259.5	62.5	124.5	50	30
	25	225.5	G1 1/4	378	200	50	0	204.5	179.5	209.5	50	30.0x5.0	155	110	250	234.5	264.5	77.5	124.5	55	30
160	10	252.5	G1 1/2	394	155	50	5	231.5	175.5	195.5	60	38.0x6.0	110	95	205	235.5	255.5	55	140.5	35	20
	16	252.5	G1 1/2	429	190	50	5	231.5	190.5	210.5	60	38.0x6.0	125	105	240	245.5	265.5	62.5	140.5	50	20
	25	252.5	G1 1/2	449	210	50	0	231.5	195.5	215.5	60	38.0x6.0	155	110	260	250.5	270.5	77.5	140.5	55	20
180	10	271.5	G1 1/2	375	155	50	5	248.5	191.5	211.5	60	38.0x6.0	110	95	205	251.5	271.5	55	156.5	35	20
	16	271.5	G1 1/2	248	190	50	5	248.5	206.5	226.5	60	38.0x6.0	125	105	240	261.5	281.5	62.5	156.5	50	20
	25	271.5	G1 1/2	307	210	50	0	248.5	211.5	231.5	60	38.0x6.0	155	110	260	266.5	286.5	77.5	156.5	55	20
200	10	285.5	G1 1/2	253	155	50	5	261.5	205.5	225.5	60	38.0x6.0	110	95	205	265.5	285.5	55	170.5	35	20
	16	285.5	G1 1/2	234	190	50	5	261.5	220.5	240.5	60	38.0x6.0	125	105	240	275.5	295.5	62.5	170.5	50	20
	25	285.5	G1 1/2	293	210	50	0	261.5	225.5	245.5	60	38.0x6.0	155	110	260	280.5	300.5	77.5	170.5	55	20

ØAL	Valve size	"Port size, porting pattern"																Position point valve	
		P	X3	h3	T	X4	h4	X	X5	h5	Y	X6	h6	MA	MB	X8	h8	X1	X2
40	6	G1/2	21.5	20	G1/2	21.5	20	-	-	-	-	-	-	-	-	-	-	25	15.5
50	6	G1/2	21.5	20	G1/2	21.5	20	-	-	-	-	-	-	-	-	-	-	25	15.5
63	6	G3/4	21.5	22.5	G3/4	21.5	22.5	-	-	-	-	-	-	-	-	-	-	35	15.5
	10	G3/4	27	33	G3/4	3.5	33	G1/4	18	57	G1/4	64.0	57	G1/4	G1/4	50	17	50	21.4
80	6	G3/4	21.5	22.5	G3/4	21.5	22.5	-	-	-	-	-	-	-	-	-	-	35	15.5
	10	G3/4	27	33	G3/4	3.5	33	G1/4	18	57	G1/4	64.0	57	G1/4	G1/4	50	17	50	21.4
100	10	G1	27	30	G1	3.5	40	G1/4	18	57	G1/4	65.0	57	G1/4	G1/4	58	20	52	21.4
125	10	G1 1/4	27	35	G1 1/4	3.5	45	G1/4	20	72	G1/4	62.0	72	G1/4	G1/4	55	25	60	21.4
	16	G1 1/4	57	35	G1 1/4	15	34	G1/4	76.5	80	G1/4	86.0	85	G1/4	G1/4	86	45	50	40
	25	G1 1/4	77	42	G1 1/4	30	34	G1/4	19	90	G1/4	109.0	90	G1/4	G1/4	103	50	50	52.1
140	10	G1 1/4	27	35	G1 1/4	3.5	45	G1/4	20	72	G1/4	62.0	72	G1/4	G1/4	55	25	60	21.4
	16	G1 1/4	57	35	G1 1/4	15	34	G1/4	76.5	80	G1/4	86.0	85	G1/4	G1/4	86	45	50	40
	25	G1 1/4	77	42	G1 1/4	30	34	G1/4	19	90	G1/4	109.0	90	G1/4	G1/4	103	50	50	52.1
160	10	G1 1/2	27	35	G1 1/2	3.5	45	G1/4	19	72	G1/4	62.0	72	G1/4	G1/4	50	25	72	21.4
	16	G1 1/2	57	35	G1 1/2	15	34	G1/4	76.5	80	G1/4	86.0	85	G1/4	G1/4	86	45	60	40
	25	G1 1/2	77	42	G1 1/2	30	34	G1/4	19	90	G1/4	109.0	90	G1/4	G1/4	103	50	60	52.1
180	10	G1 1/2	27	35	G1 1/2	3.5	45	G1/4	19	72	G1/4	62.0	72	G1/4	G1/4	50	25	72	21.4
	16	G1 1/2	57	35	G1 1/2	15	34	G1/4	76.5	80	G1/4	86.0	85	G1/4	G1/4	86	45	60	40
	25	G1 1/2	77	42	G1 1/2	30	34	G1/4	19	90	G1/4	109.0	90	G1/4	G1/4	103	50	60	52.1
200	10	G1 1/2	27	35	G1 1/2	3.5	45	G1/4	19	72	G1/4	62.0	72	G1/4	G1/4	50	25	72	21.4
	16	G1 1/2	57	35	G1 1/2	15	34	G1/4	76.5	80	G1/4	86.0	85	G1/4	G1/4	86	45	60	40
	25	G1 1/2	77	42	G1 1/2	30	34	G1/4	19	90	G1/4	109.0	90	G1/4	G1/4	103	50	60	52.1

1) Not for MT4

2) Only for MT4

### Bleeding / measuring coupling (dimensions in mm)

By default, a patented safety vent against unintended screwing out in head and base is delivered for all cylinders.

The port allows for the installation of a measuring coupling with check valve for pressure measurement or contamination-free bleeding. Measuring coupling with check valve function, i.e. the measuring or bleeding hose can also be connected when the system is pressurized.

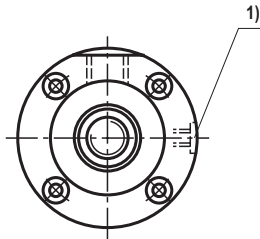

1) Bleeding: With view to the piston rod, the position is offset by 90° in relation to the line connection (clockwise)

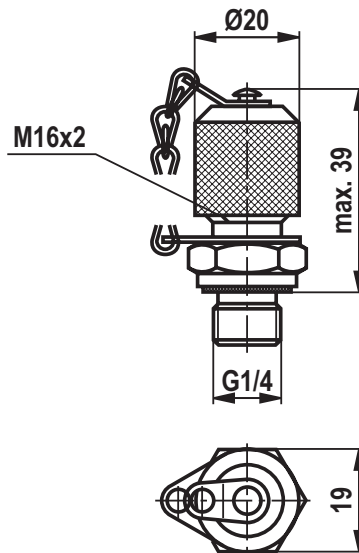
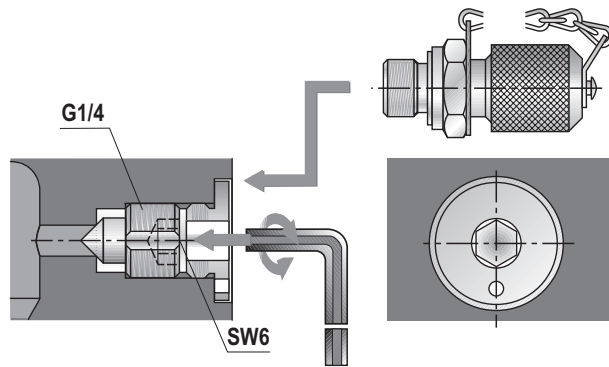

Scope of delivery: Measuring coupling **G1/4**

MESSKUPPLUNG AB 20-11/K1 G1/4 with seal ring made of NBR

Material no. **R900009090**

MESSKUPPLUNG AB 20-11/K1V G1/4 with seal ring made of FKM

Material no. **R900001264**

### Throttle valve (dimensions in mm)

ØAL	40	50	63	80	100	125	140	160	180	200	220	250	280	320
Nominal width	4	4	4	5	5	8	8	8	8	8	20	20	20	20

ØAL = Piston Ø

1) Throttle valve only with end position cushioning "E" (180° for bleeding)

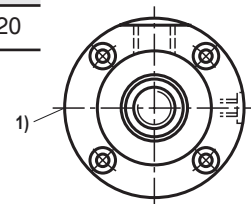

## Proximity switch

Inductive proximity switches are used as reliable end position control for hydraulic cylinders. They are an important element for the safe and exact monitoring of safety equipment, locks and/or other machine functions in their end position by means of the output of signals. The proximity switch which is high-pressure resistant up to 500 bar works in a contactless

manner. Consequently, it is wear-free. The proximity switch has been set at the factory. The switching distance must not be adjusted. The lock nut of the proximity switch is marked at the factory using sealing wax. On versions with proximity switch, the cylinders are equipped with proximity switches on both sides.

### Technical data (For applications outside these parameters, please consult us.)

Function type		PNP normally open contact
Admissible pressure	bar	500
Operating voltage	V DC	10 ... 30
	including residual ripple	%
		≤ 15
Voltage drop	V	≤ 1,5
Rated operating voltage	V DC	24
Rated operating current	mA	200
Idle current	mA	≤ 8
Residual current	μA	≤ 10
Repetition accuracy	%	≤ 5
Hysteresis	%	≤ 15
Ambient temperature range	°C	-25 ... +80
Temperature drift	%	≤ 10
Switching frequency	Hz	1000
Protection class	active area	IP 68
	Proximity switch	IP 67
Housing material		Material no. 1.4104

### Pin assignment

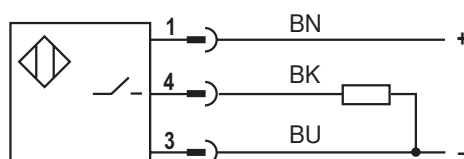

BN brown  
BK black  
BU blue

## Proximity switch

### CDH3

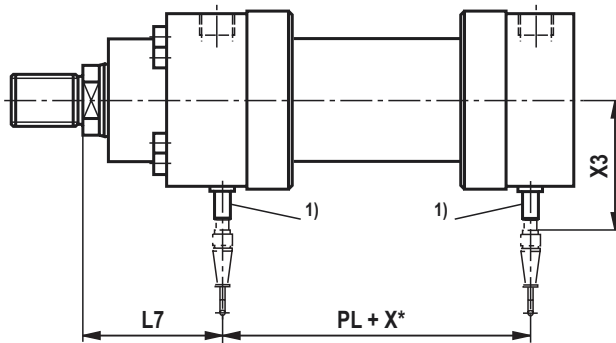

### CGH3

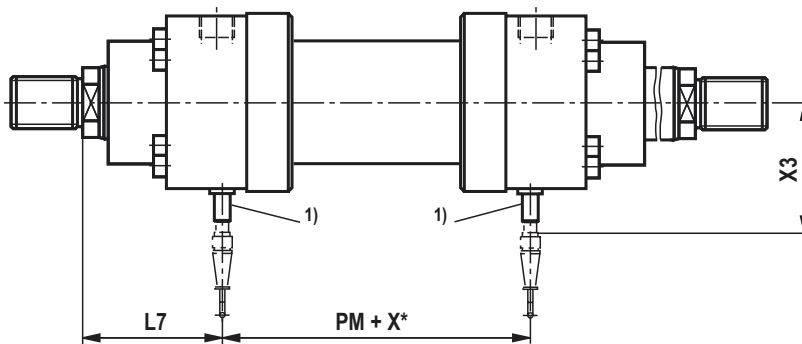

### Installation space for mating connector

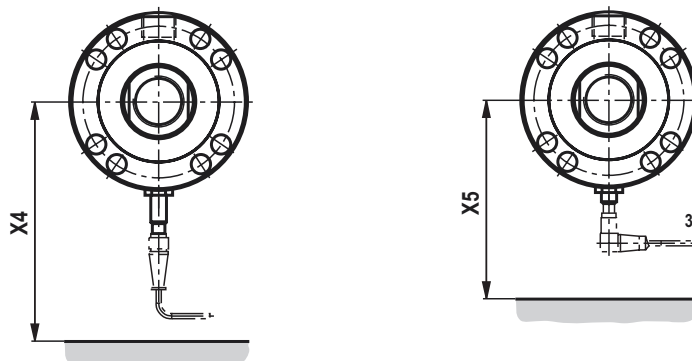

#### Mating connector with 5 m cable

Material no. **R913016852**

(mating connector is **not** included in the scope of delivery, must be ordered separately)



#### Mating connector, angled with 5 m cable

(position of the cable outlet cannot be defined)

Material no. **R988064311**

(mating connector is **not** included in the scope of delivery, must be ordered separately)

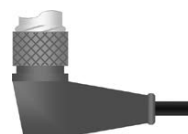

## Proximity switch

Dimensions (dimensions in mm)

ØAL	ØMM	PL	PM	L7	X3	X4	X5
40	28	112	112	95	94	170	125
50	36	110	110	95	98	175	130
63	45	125	125	121	103	180	135
80	56	138	138	128	108	185	140
100	70	161	161	124	116	195	150
125	90	189	189	178	126	205	160
140	100	209	209	191	146	225	180
160	110	228	228	216	151	230	185
180	125	254	254	246	159 <sup>2)</sup>	235	190
200	140	264	264	269	166 <sup>2)</sup>	245	200
220	160	310	310	270	177 <sup>2)</sup>	255	– <sup>3)</sup>
250	180	320	320	280	187 <sup>2)</sup>	265	– <sup>3)</sup>
280	200	360	360	285	199 <sup>2)</sup>	275	– <sup>3)</sup>
320	220	375	375	295	209 <sup>2)</sup>	285	– <sup>3)</sup>

Main dimensions see pages 10 to 21

ØAL = Piston Ø

ØMM = Piston rod Ø

X\* = Stroke length

1) The proximity switch is always located opposite of the line connection

2) Piston Ø 220 - 320 mm  
Proximity switch not protruding

3) Piston Ø 220 - 320 mm  
Angled mating connector not possible

## Position measurement system

The position measurement system that is pressure-resistant up to 500 bar works in a contactless and absolute manner. The basis of this position measurement system is the magnetostrictive effect. Here, the coincidence of two magnetic fields triggers a torsional impulse.

This impulse runs on the wave guide inside the scale from the measuring point to the sensor head. The running time is constant and almost independent of temperature. It is proportional to the solenoid position and thus a measure for the actual position value and is converted within the sensor into a direct analog or digital output.

### Technical data (For applications outside these parameters, please consult us.)

Operating pressure		bar	350
Analog output		V	0 to 10
	Load resistance	k $\Omega$	$\geq 5$
	Resolution		unlimited
Analog output		mA	4 to 20
	Load resistance	$\Omega$	0 to 500
	Resolution		unlimited
Digital output			SSI 24 bit gray-coded
	Resolution	$\mu\text{m}$	5
	Direction of measurement		asynchronously forward
Linearity (absolute accuracy)	Analog	% mm	$\leq \pm 0.02\%$ (referred to measurement length) min. $\pm 0.05$
	Digital	% mm	$\leq \pm 0.01\%$ (referred to measurement length) min. $\pm 0.04$
Reproducibility		% mm	$\pm 0.001$ (referred to measurement length) min. $\pm 0.0025$
Hysteresis		mm	$\leq 0.004$
Supply voltage		V DC	24 ( $\pm 10\%$ with analog output)
	Current consumption	mA	100
	Residual ripple	% s-s	$\leq 1$
	Current consumption	V DC mA	24 (+20 %/-15 % with digital output) 70
	Residual ripple	% s-s	$\leq 1$
Protection class	Pipe and flange		IP 67
	Sensor electronics		IP 65
Operating temperature	Sensor electronics	$^{\circ}\text{C}$	-40 to +75
Temperature coefficient	Voltage	ppm/ $^{\circ}\text{C}$	70
	Current	ppm/ $^{\circ}\text{C}$	90

## Position measurement system

### Types of mounting

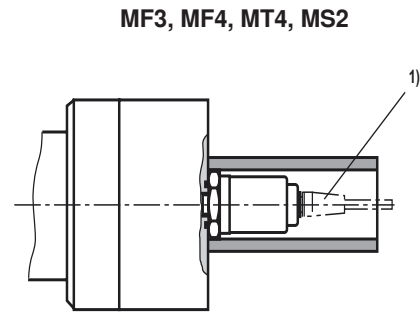
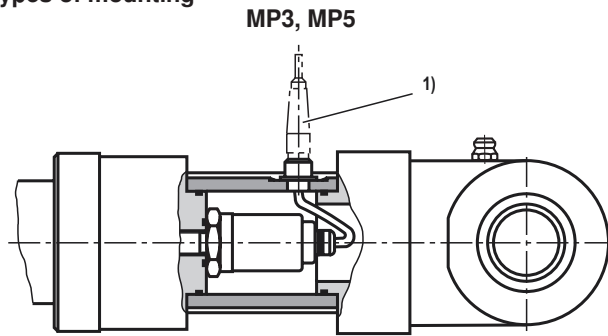

1) For analog output:

6-pole Amphenol mating connector

Material no. **R900072231**

(mating connector is **not** included in the scope of delivery, must be ordered separately)



1) For digital output:

7-pole Amphenol mating connector

Material no. **R900079551**

(mating connector is **not** included in the scope of delivery, must be ordered separately)



### Pin assignment

#### Position measurement system (analog output)

Connector (view to pin side)

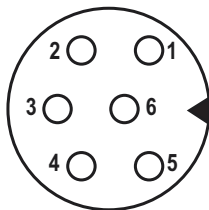

Pin	Cable	Signal / current	Signal / voltage
1	gray	4 ... 20 mA	0 ... 10 V
2	pink	DC ground	DC ground
3	yellow	not used	not used
4	green	DC ground	DC ground
5	brown	+24 V DC (+20 % / -15 %)	+24 V DC (+20 % / -15 %)
6	white	DC ground (0 V)	DC ground (0 V)

#### Position measurement system (digital output)

Connector (view to pin side)

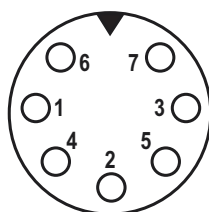

Pin	Cable	Signal / SSI
1	gray	Data (-)
2	pink	Data (+)
3	yellow	Clock (+)
4	green	Clock (-)
5	brown	+24 V DC (+20 % / -15 %)
6	white	DC ground (0 V)
7	-	not used

**Technical data for the Profibus** (For applications outside these parameters, please consult us!)

Output	Interface	Profibus-DP system
	Data record	Profibus-DP (EN 61158)
	Transmission rate	Max. 12 Mbit/s
Measurement accuracy	Travel resolution	1 $\mu\text{m}$ to 1000 $\mu\text{m}$ selectable as parameter
	Velocity	With 5 $\mu\text{m}$ travel resolution: 0.64 mm/s to 500 mm; 0.43 mm/s to 2000 mm; 0.21 mm/s to 4500 mm; 0.14 mm/s to 7600 mm Measurement length With 2 $\mu\text{m}$ travel resolution: 2.5 times smaller values
	Linearity	< $\pm 0.01\%$ Full Scale (Minimum $\pm 50\ \mu\text{m}$ )
	Repeatability	< $\pm 0.001\%$ Full Scale (Minimum $\pm 2.5\ \mu\text{m}$ )
	Temperature coefficient	< 15 ppm/ $^{\circ}\text{C}$
	Hysteresis	< 4 $\mu\text{m}$
	Application conditions	Operating temperature
	Protection class	Profile: IP 65 Rod: IP 67 with appropriate coupling plug assembly
	Standards, EMC test	Interference emissions according to EN 61000-6-3 Interference resistance according to EN 61000-6-2 EN 61000-4-2/3/4/6, level 3/4, criterion A, CE-tested
Electrical connection	Operating voltage	24 V DC (-15 / +20 %)

Please ask for the complete technical data!

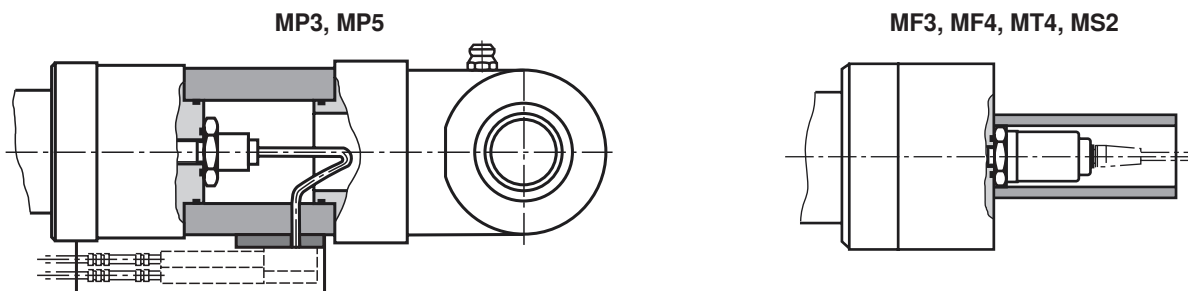
**Types of mounting**

The output of the position measurement system is by default always rotated by 180° to the selected position of the hydraulic connection in the cylinder base.

Mating connector is **not** included in the scope of delivery, must be ordered separately.



## Pin assignment for Profibus

### Pin assignment for Profibus D63

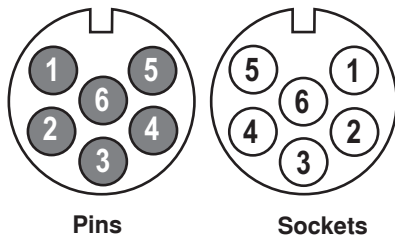

Pin	Cable	Function
1	green	RxD/TxD-N (bus)
2	red	RxD/TxD-P (bus)
3	—	DGND (terminating resistor) *
4	—	VP (terminating resistor) *
5	black	+24 V DC (-15 / +20 %)
6	blue	DC ground (0 V)
—	yellow/ green	Shield compensating line, is usually not to be connected

\* only with sockets

### Mating connectors for D63



Signal input  
6-pole mating connector M16  
Material no. R900705950 (socket)

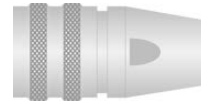

Signal output  
6-pole end plug M16  
Material no. R900722518 (pins)



Signal output  
6-pole mating connector M16  
Material no. R900705951 (pins)

### Pin assignment for Profibus D53

#### Bus

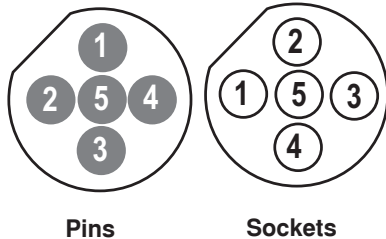

Pin	Cable	Function
1	—	VP+5 (terminating resistor) *
2	green	RxD/TxD-N (bus)
3	—	DGND (terminating resistor) *
4	red	RxD/TxD-P (bus)
5	Shield	Shield

\* only with sockets

### Supply

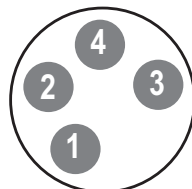

Pin	Cable	Function
1	brown	+24 V DC (-15 / +20 %)
2	white	not used
3	blue	DC ground (0 V)
4	black	not used

#### View connector side

### Mating connectors for D53



Signal input  
5-pole mating connector M12-B  
Material no. R900773386 (socket)

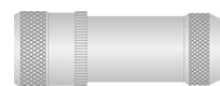

4-pole mating connector M8  
Material no. R901132799



Signal output  
5-pole mating connector M12-B  
Material no. R901091655 (pins)



Connection cable 5 m  
with 4-pole mating connector M8  
Material no. R901213191



Signal output  
5-pole end plug M12-B  
Material no. R901070126 (pins)

Connection cable 10 m  
with 4-pole mating connector M8  
Material no. R913008737

Connection cable 15 m  
with 4-pole mating connector M8  
Material no. R913008738

Mating connector is **not** included in the scope of delivery, must be ordered separately.

## Plain clevis CSA (dimensions in mm)

ØAL 40 to 200 mm

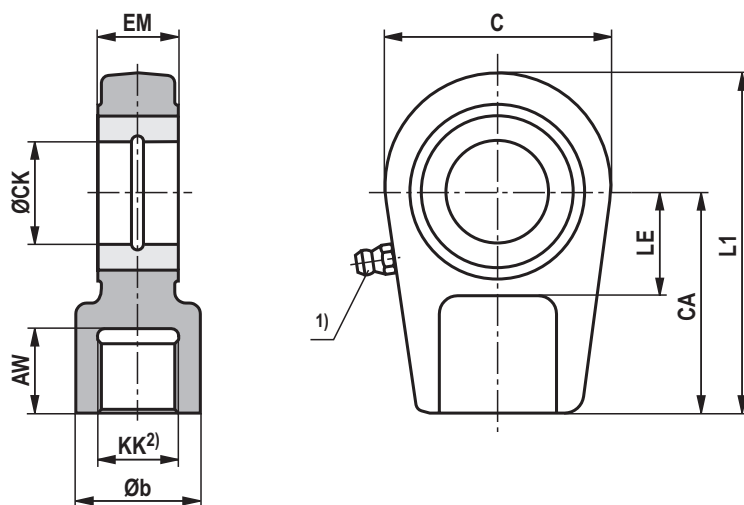

ØAL	Type	Material no.	AW	Øb	C	CA	ØCK H11	EM -0.4	KK	LE	L1	$m$ <sup>3)</sup> kg	$C_0$ <sup>4)</sup> kN	$F_{adm}$ <sup>5)</sup> kN
40	CSA 22	R900303151	23	34	64	60	30	28	M22x1.5	30	94	0.7	106	38.2
50	CSA 28	R900303152	29	44	78	70	35	30	M28x1.5	40	112	1.1	153	55.1
63	CSA 35	R900303153	36	55	94	85	40	35	M35x1.5	45	135	2.0	250	90.0
80	CSA 45	R900303154	46	70	116	105	50	40	M45x1.5	55	168	3.3	365	131.4
100	CSA 58	R900303155	59	87	130	130	60	50	M58x1.5	65	200	5.5	400	144.0
125	CSA 65	R900303156	66	93	154	150	70	55	M65x1.5	75	232	8.6	540	194.4
140	CSA 80	R900303157	81	125	176	170	80	60	M80x2	80	265	12.2	670	241.2
160	CSA100	R900303158	101	143	206	210	90	65	M100x2	90	323	21.5	980	352.8
180	CSA110	R900303159	111	153	230	235	100	70	M110x2	105	360	27.5	1120	403.2
200	CSA120	R900303160	125	176	265	265	110	80	M120x3	115	407.5	40.7	1700	612.0

The specified dimensions are maximum values and may differ depending on the manufacturer.

The following values are excluded: CA, CK, EM, KK

ØAL = Piston Ø

- 1) Lubricating nipple, cone head form A according to DIN 71412
- 2) The plain clevis must always be screwed against the piston rod shoulder
- 3)  $m$  = Weight of plain clevis in kg
- 4)  $C_0$  = Static load rating of the plain clevis
- 5)  $F_{adm}$  = Max. admissible load of the plain clevis for oscillatory or alternating loads

## Swivel head CGA (dimensions in mm)

ØAL 40 to 250 mm

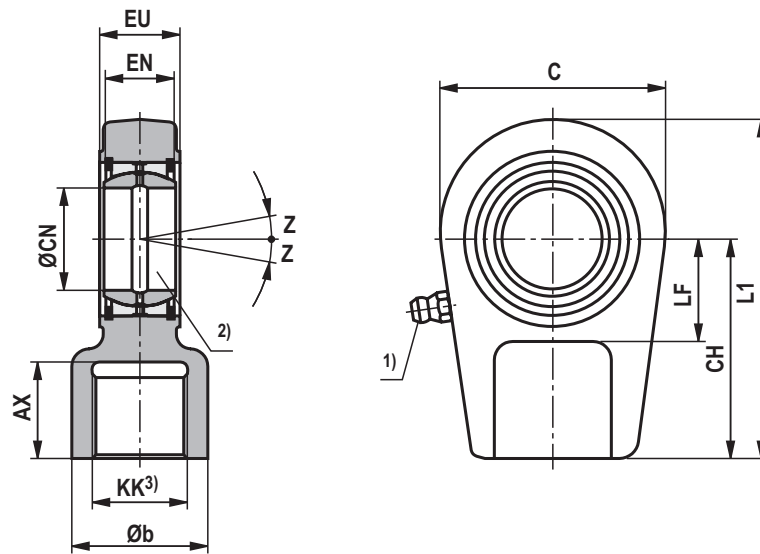

ØAL	Type	AX min	Øb max	C	CH	ØCN <sup>2)</sup>	EN	EU -0.4	KK	L1	LF min	Z	m <sup>4)</sup> kg
40	CGA22	23	33	64	60	30 <sub>-0.010</sub>	22 <sub>-0.12</sub>	28	M22x1.5	94	30	6°	0.7
50	CGA28	29	41	78	70	35 <sub>-0.012</sub>	25 <sub>-0.12</sub>	30	M28x1.5	112	38	6°	1.1
63	CGA35	36	50	94	85	40 <sub>-0.012</sub>	28 <sub>-0.12</sub>	35	M35x1.5	135	45	7°	2.0
80	CGA45	46	62	116	105	50 <sub>-0.012</sub>	35 <sub>-0.12</sub>	40	M45x1.5	168	55	6°	3.3
100	CGA58	59	76	130	130	60 <sub>-0.015</sub>	44 <sub>-0.15</sub>	50	M58x1.5	200	65	6°	5.5
125	CGA65	66	87	154	150	70 <sub>-0.015</sub>	49 <sub>-0.15</sub>	55	M65x1.5	232	75	6°	8.6
140	CGA80	81	106	176	170	80 <sub>-0.015</sub>	55 <sub>-0.15</sub>	60	M80x2	265	80	6°	12.2
160	CGA100	101	125	206	210	90 <sub>-0.020</sub>	60 <sub>-0.20</sub>	65	M100x2	323	90	5°	21.5
180	CGA110	111	139	230	235	100 <sub>-0.020</sub>	70 <sub>-0.20</sub>	70	M110x2	360	105	7°	27.5
200	CGA120	125	153	265	265	110 <sub>-0.020</sub>	70 <sub>-0.20</sub>	80	M120x3	407.5	115	6°	40.7
220	CGA120	125	153	265	265	110 <sub>-0.020</sub>	70 <sub>-0.20</sub>	80	M120x3	407.5	115	6°	40.7
250	CGA130	135	173	340	310	120 <sub>-0.020</sub>	85 <sub>-0.20</sub>	90	M130x3	490	140	6°	76.4

ØAL	Type	Material no. requiring maintenance	Material no. maintenance- free	C <sub>0</sub> <sup>5)</sup> kN	F <sub>adm</sub> <sup>6)</sup> kN
40	CGA22	R900303126	R900321695	106	38.2
50	CGA28	R900303127	R900321653	153	55.1
63	CGA35	R900303128	R900321694	250	90.0
80	CGA45	R900303129	R900321667	365	131.4
100	CGA58	R900303130	R900321693	400	144.0
125	CGA65	R900303131	R900323345	540	194.4
140	CGA80	R900303132	R900321669	670	241.2
160	CGA100	R900303133	R900323349	980	352.8
180	CGA110	R900303134	R900868406	1120	403.2
200	CGA120	R900303135	R900321668	1700	612.0
220	CGA120	R900303135	R900321668	1700	612.0
250	CGA130	R900303136	upon request	2900	1044.0

The specified dimensions are maximum values and may differ depending on the manufacturer.

The following values are excluded: CH, CN, EN, EU, KK

ØAL = Piston Ø

- 1) Lubricating nipple, cone head form A according to DIN 71412;  
not applicable to spherical bearing, maintenance-free "A"
- 2) Related bolt Ø m6;  
Related bolt Ø j6 for maintenance-free spherical bearing
- 3) The swivel head must always be screwed against the piston rod shoulder
- 4) **m** = Weight of swivel head in kg
- 5) **C<sub>0</sub>** = Static load rating of the swivel head
- 6) **F<sub>adm</sub>** = Max. admissible load on the swivel head during oscillatory or alternating loads

## Swivel head CGAK (clampable) (dimensions in mm)

ØAL 40 to 250 mm

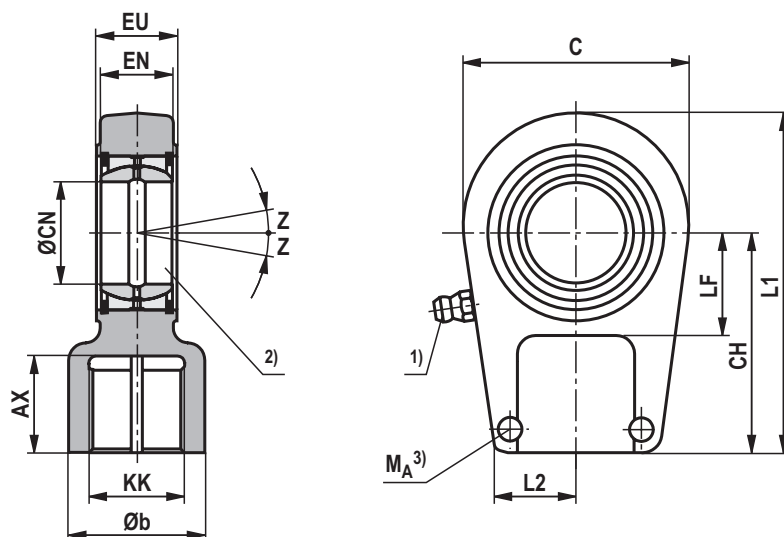

ØAL	Type	AX min	Øb max	C	CH	ØCN <sup>2)</sup>	EN	EU -0.4	KK
40	CGAK22	23	33	64	60	30 <sub>-0.010</sub>	22 <sub>-0.12</sub>	28	M22x1.5
50	CGAK28	29	41	78	70	35 <sub>-0.012</sub>	25 <sub>-0.12</sub>	30	M28x1.5
63	CGAK35	36	50	94	85	40 <sub>-0.012</sub>	28 <sub>-0.12</sub>	35	M35x1.5
80	CGAK45	46	62	116	105	50 <sub>-0.012</sub>	35 <sub>-0.12</sub>	40	M45x1.5
100	CGAK58	59	76	130	130	60 <sub>-0.015</sub>	44 <sub>-0.15</sub>	50	M58x1.5
125	CGAK65	66	87	154	150	70 <sub>-0.015</sub>	49 <sub>-0.15</sub>	55	M65x1.5
140	CGAK80	81	106	176	170	80 <sub>-0.015</sub>	55 <sub>-0.15</sub>	60	M80x2
160	CGAK100	101	125	206	210	90 <sub>-0.020</sub>	60 <sub>-0.20</sub>	65	M100x2
180	CGAK110	111	139	231	235	100 <sub>-0.020</sub>	70 <sub>-0.20</sub>	70	M110x2
200	CGAK120	125	155	266	265	110 <sub>-0.020</sub>	70 <sub>-0.20</sub>	80	M120x3
220	CGAK120	125	153	265	265	110 <sub>-0.020</sub>	70 <sub>-0.20</sub>	80	M120x3
250	CGAK130	135	173	340	310	120 <sub>-0.020</sub>	85 <sub>-0.20</sub>	90	M130x3

ØAL	Type	Material no. requiring maintenance	Material no. maintenance- free	C <sub>0</sub> <sup>5)</sup> kN	F <sub>adm</sub> <sup>6)</sup> kN
40	CGAK22	R900303163	R900321683	106	38.2
50	CGAK28	R900303164	R900300717	153	55.1
63	CGAK35	R900303165	R900322738	250	90.0
80	CGAK45	R900303166	R900322019	365	131.4
100	CGAK58	R900303167	R900322020	400	144.0
125	CGAK65	R900303168	R900324812	540	194.4
140	CGAK80	R900303169	R900541157	670	241.2
160	CGAK100	R900332655	R900323305	980	352.8
180	CGAK110	R900321691	R900329997	1120	403.2
200	CGAK120	R900321621	R900323333	1700	612.0
220	CGAK120	R900321621	R900323333	1700	612.0
250	CGAK130	R900322015	R900540850	2900	1044.0

## Swivel head CGAK (clampable) (dimensions in mm)

$\varnothing$ AL	Type	L1	L2 max	LF	Z	Clamping screws ISO 4762-10.9	$M_A$ <sup>3)</sup> Nm	$m$ <sup>4)</sup> kg
40	CGAK 22	94	26	30	6°	M8	30	0.7
50	CGAK 28	112	34	38	6°	M10	54	1.1
63	CGAK 35	135	39	45	7°	M10	59	2.0
80	CGAK 45	168	46	55	6°	M12	100	3.3
100	CGAK 58	200	61	65	6°	M16	250	5.5
125	CGAK 65	232	66	75	6°	M16	250	8.6
140	CGAK 80	265	81	80	6°	M20	490	12.2
160	CGAK100	323	91	90	5°	M20	490	21.5
180	CGAK110	360	101	105	7°	M24	840	27.5
200	CGAK120	407.5	111	115	6°	M24	840	40.7
220	CGAK120	407.5	111	115	6°	M24	840	40.7
250	CGAK130	490	129	140	6°	M24	840	76.4

The specified dimensions are maximum values and may differ depending on the manufacturer.  
The following values are excluded: CH, CN, EN, EU, KK

$\varnothing$ AL = Piston  $\varnothing$

- 1) Lubricating nipple, cone head form A according to DIN 71412;  
not applicable to spherical bearing, maintenance-free "A"
- 2) Related bolt  $\varnothing$  m6;  
Related bolt  $\varnothing$  j6 for maintenance-free spherical bearing
- 3)  $M_A$  = Tightening torque  
The swivel head must always be screwed against the piston rod shoulder.  
Afterwards, the clamping screws must be tightened with the specified tightening torque.
- 4)  $m$  = Weight of swivel head in kg
- 5)  $C_0$  = Static load rating of the swivel head
- 6)  $F_{adm}$  = Max. admissible load on the swivel head during oscillatory or alternating loads

## Swivel head CGAS (clampable) (dimensions in mm)

ØAL 40 to 320 mm

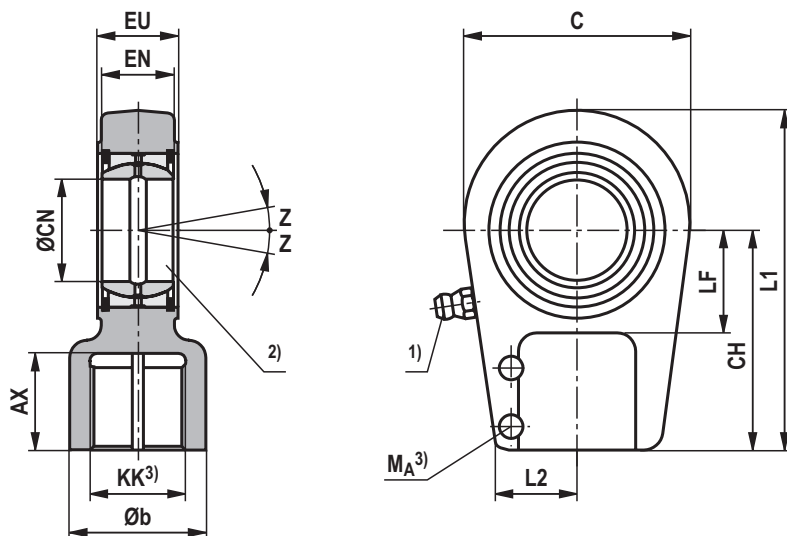

ØAL	Type	AX min	Øb max	C max	CH	ØCN <sup>2)</sup>	EN	EU -0.4	KK
40	CGAS30	35	34	64	75	30 <sub>-0.010</sub>	22 <sub>-0.12</sub>	28	M24x2
50	CGAS35	46	46	78	90	35 <sub>-0.012</sub>	25 <sub>-0.12</sub>	30	M30x2
63	CGAS40	56	57	94	105	40 <sub>-0.012</sub>	28 <sub>-0.12</sub>	35	M39x3
80	CGAS50	76	70	116	135	50 <sub>-0.012</sub>	35 <sub>-0.12</sub>	40	M50x3
100	CGAS60	96	87	130	170	60 <sub>-0.015</sub>	44 <sub>-0.15</sub>	50	M64x3
125	CGAS70	112	111	154	195	70 <sub>-0.015</sub>	49 <sub>-0.15</sub>	55	M80x3
140	CGAS80	122	129	176	210	80 <sub>-0.015</sub>	55 <sub>-0.15</sub>	60	M90x3
160	CGAS90	142	153	211	250	90 <sub>-0.020</sub>	60 <sub>-0.20</sub>	65	M100x3
180	CGAS100	152	170	230	275	100 <sub>-0.020</sub>	70 <sub>-0.20</sub>	70	M110x4
200	CGAS110	162	180	264	300	110 <sub>-0.020</sub>	70 <sub>-0.20</sub>	80	M120x4
220	CGAS110	162	180	264	300	110 <sub>-0.020</sub>	70 <sub>-0.20</sub>	80	M120x4
250	CGAS120	192	210	340	360	120 <sub>-0.020</sub>	85 <sub>-0.20</sub>	90	M150x4
280	CGAS140	210	230	380	420	140 <sub>-0.025</sub>	90 <sub>-0.25</sub>	110	M160x4
320	CGAS160	221	260	480	460	160 <sub>-0.025</sub>	105 <sub>-0.25</sub>	110	M180x4

ØAL	Type	Material no. requiring maintenance	Material no. maintenance- free	C <sub>0</sub> <sup>6)</sup> kN	F <sub>adm</sub> <sup>7)</sup> kN
40	CGAS30	R900303138	R900321696	122	40.3
50	CGAS35	R900303139	R900322716	177	58.4
63	CGAS40	R900303140	R900321665	287	94.7
80	CGAS50	R900303141	R900322017	422	139.3
100	CGAS60	R900303142	R900321685	522	172.3
125	CGAS70	R900303143	R900321690	707	233.3
140	CGAS80	R900303144	R900322022	870	287.1
160	CGAS90	R900303145	R900323344	1284	423.7
180	CGAS100	R900303146	R900321689	1460	481.8
200	CGAS110	R900303147	R900323326	2024	667.9
220	CGAS110	R900303147	R900323326	2024	667.9
250	CGAS120	R900303148	R900324830	2970	980.1
280	CGAS140	R900317314	R900540515	3350	1105.5
320	CGAS160	R900303149	R900322725	4302	1419.7

## Swivel head CGAS (clampable) (dimensions in mm)

$\varnothing$ AL	Type	L1 max	L2 max	LF min	Z <sup>3)</sup>	Clamping screws ISO 4762-10.9	$M_A$ <sup>4)</sup> Nm	$m$ <sup>5)</sup> kg
40	CGAS 30	109	28	30	6-7°	M8	30	1.0
50	CGAS 35	132	36	40	6-7°	M10	59	1.5
63	CGAS 40	155	39	44	7°	M12	100	2.4
80	CGAS 50	198	45	55	6-7°	M12	100	4.8
100	CGAS 60	240	59	65	6-7°	M16	250	8.6
125	CGAS 70	279	70	75	6°	M16	250	12.2
140	CGAS 80	305	85	80	6°	M20	490	18.4
160	CGAS 90	366	91	90	5°	M20	490	31.6
180	CGAS100	400	95	105	7°	M20	490	34
200	CGAS110	443	106	115	6°	M24	840	44
220	CGAS110	443	106	115	6°	M24	840	44
250	CGAS120	540	122	140	6°	M24	840	75
280	CGAS140	620	129	185	7°	M30	1700	160
320	CGAS160	710	146	200	8°	M30	1700	235

The specified dimensions are maximum values and may differ depending on the manufacturer.  
The following values are excluded: CH, CN, EN, EU, KK

$\varnothing$ AL = Piston  $\varnothing$

- 1) Lubricating nipple, cone head form A according to DIN 71412;  
not applicable to spherical bearing, maintenance-free "A"
- 2) Related bolt  $\varnothing$  m6;  
Related bolt  $\varnothing$  j6 for maintenance-free spherical bearing
- 3)  $M_A$  = Tightening torque  
The swivel head must always be screwed against the piston rod shoulder.  
Afterwards, the clamping screws must be tightened with the specified tightening torque.
- 4)  $m$  = Weight of swivel head in kg
- 5)  $C_0$  = Static load rating of the swivel head
- 6)  $F_{adm}$  = Max. admissible load on the swivel head during oscillatory or alternating loads

## Kinking

For the admissible stroke length with flexibly guided load and a factor of 3.5 for safety against kinking, please refer to the relevant table. For other installation positions of the cylinder, the admissible stroke length must be interpolated. Admissible stroke length for non-guided load on request.

Kinking calculations are carried out according to the following formulas:

### 1. Calculation according to Euler

$$F = \frac{\pi^2 \cdot E \cdot I}{v \cdot L_K^2} \quad \text{if } \lambda > \lambda_g$$

### 2. Calculation according to Tetmajer

$$F = \frac{d^2 \cdot \pi (335 - 0.62 \cdot \lambda)}{4 \cdot v} \quad \text{if } \lambda \leq \lambda_g$$

### Explanation:

$E$  = Module of elasticity in N/mm<sup>2</sup>

=  $2.1 \times 10^5$  for steel

$I$  = Geometrical moment of inertia in mm<sup>4</sup>

for circular cross-section =  $\frac{d^4 \cdot \pi}{64} = 0.0491 \cdot d^4$

$v$  = 3.5 (safety factor)

$L_K$  = Free bending length in mm (depending on the type of mounting see sketches A, B, C)

$d$  = Piston rod Ø in mm

$\lambda$  = Slenderness ratio

$$= \frac{4 \cdot L_K}{d} \quad \lambda_g = \pi \sqrt{\frac{E}{0.8 \cdot R_e}}$$

$R_e$  = yield strength of the piston rod material

Influence of the type of mounting on the bending length:

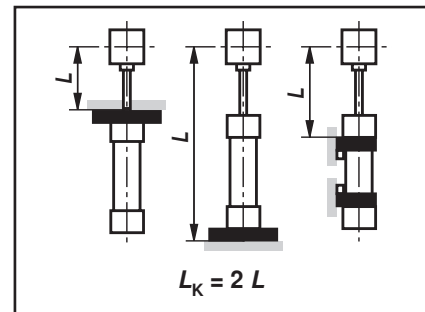
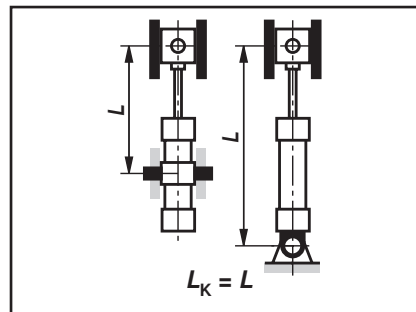
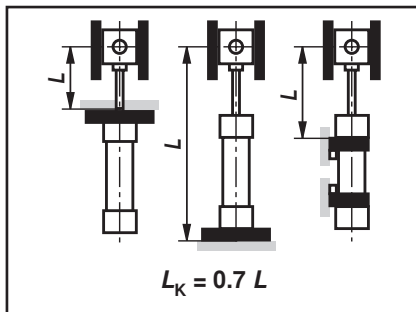

## Admissible stroke length (dimensions in mm)

Type of mounting CDH3/CSH3 <sup>2)</sup>: MP3, MP5

ØAL	ØMM	admissible stroke length with									Installation position
		100 bar			210 bar			350 bar			
		0°	45°	90°	0°	45°	90°	0°	45°	90°	
40	28	360	375	420	225	230	240	140	145	150	
50	36	505	525	351	335	340	355	230	235	240	
63	45	625	650	755	425	430	455	295	300	305	
80	56	765	800	945	530	545	575	375	380	390	
100	70	950	995	1200	680	695	745	495	500	515	
125	90	1200	1270	1610	895	925	1010	665	680	705	
140	100	1335	1405	1785	995	1025	1125	745	755	790	
160	110	1380	1406	1865	1025	1055	1160	755	770	805	
180	125	1580	1670	2150	1180	1220	1350	880	895	940	
200	140	1780	1890	2470	1355	1400	1565	1035	1055	1110	
220	160	1985	2110	2970	1575	1640	1900	1230	1260	1360	
250	180	2190	2340	3310	1740	1820	2120	1370	1400	1510	
280	200	2360	2520	3640	1890	1970	2330	1490	1530	1660	
320	220	2530	2700	3830	2010	2100	2450	1320	1460	1740	1) Adm. stroke length



## Admissible stroke length (dimensions in mm)

Type of mounting CDH3/CGH3/CSH3 <sup>2)</sup>: MF3

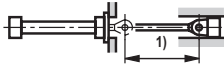
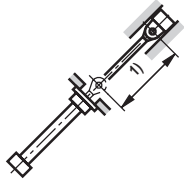
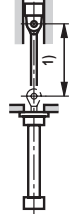
ØAL	ØMM	admissible stroke length with									Installation position
		100 bar			210 bar			350 bar			
		0°	45°	90°	0°	45°	90°	0°	45°	90°	
40	28	1370	1415	1600	1020	1035	1075	795	800	810	0° 
50	36	1755	1825	2135	1345	1370	1440	1060	1070	1090	
63	45	2000	2000	2000	1660	1695	1800	1320	1330	1365	
80	56	2000	2000	2000	2000	2000	2000	1600	1620	1665	45° 
100	70	3000	3000	3000	2470	2530	2740	1900	2010	2085	
125	90	3000	3000	3000	3000	3000	3000	2615	2660	2785	
140	100	3000	3000	3000	3000	3000	3000	2875	2920	3000	
160	110	3000	3000	3000	3000	3000	3000	2775	3000	3000	
180	125	3000	3000	3000	3000	3000	3000	3000	3000	3000	90° 
200	140	3000	3000	3000	3000	3000	3000	3000	3000	3000	
220	160	6000	6000	6000	5410	5630	6000	4575	4675	5055	
250	180	6000	6000	6000	5950	6000	6000	4815	5160	5605	
280	200	6000	6000	6000	6000	6000	6000	5005	5565	6000	
320	220	6000	6000	6000	6000	6000	6000	4560	5060	6000	

Type of mounting CDH3/CSH3 <sup>2)</sup>: MF4

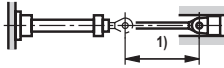
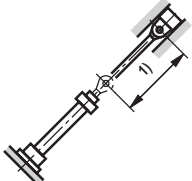
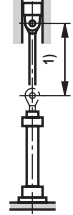

ØAL	ØMM	admissible stroke length with									Installation position
		100 bar			210 bar			350 bar			
		0°	45°	90°	0°	45°	90°	0°	45°	90°	
40	28	540	565	675	380	385	410	270	275	280	0° 
50	36	735	770	940	540	550	590	400	405	415	
63	45	900	945	1175	670	690	745	505	510	530	
80	56	1080	1140	1450	825	845	930	630	635	665	45° 
100	70	1330	1400	1840	1030	1070	1190	805	820	860	
125	90	1655	1760	2450	1330	1380	1590	1060	1080	1160	
140	100	1830	1940	2700	1470	1530	1760	1175	1200	1285	
160	110	1905	2030	2830	1530	1590	1835	1035	1160	1300	
180	125	2210	2355	3310	1795	1870	2170	1285	1435	1585	90° 
200	140	2400	2565	3000	1965	2050	2420	1410	1590	1765	
220	160	2655	2850	4445	2245	2360	2935	1735	1930	2160	
250	180	2945	3160	4950	2490	2620	3275	1840	2095	2410	
280	200	3170	3410	5455	2705	2850	3615	1870	2140	2665	
320	220	3425	3680	5775	2905	3055	3820	1675	1925	2815	

## Admissible stroke length (dimensions in mm)

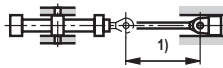
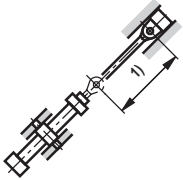
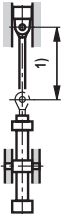
### Type of mounting CDH3/CGH3/CSH3 <sup>2)</sup>: MT4 trunnion in cylinder center

ØAL	ØMM	admissible stroke length with									Installation position
		100 bar			210 bar			350 bar			
		0°	45°	90°	0°	45°	90°	0°	45°	90°	
40	28	560	580	640	380	385	395	265	270	275	0° 
50	36	760	790	890	353	545	565	390	395	400	
63	45	930	965	1105	665	675	705	490	495	505	
80	56	1125	1170	1365	815	830	875	610	615	625	45° 
100	70	1390	1450	1730	1030	1050	1120	785	790	810	
125	90	1755	1845	2300	1345	1380	1500	1040	1050	1090	
140	100	1935	2030	2545	1485	1525	1660	1150	1165	1210	
160	110	2020	2125	2660	1545	1585	1725	1190	1205	1250	
180	125	2300	2420	3000	1770	1820	1990	1370	1390	1445	90° 
200	140	2555	2695	3000	1990	2050	2270	1555	1580	1655	
220	160	2870	3045	4185	2320	2410	2760	1865	1905	2035	
250	180	3180	3380	4665	2580	2680	3080	2080	2125	2270	
280	200	3430	3645	5130	2800	2915	3390	2270	2325	2500	
320	220	3700	3925	5435	3000	3115	3585	2065	2295	2640	1) Adm. stroke length

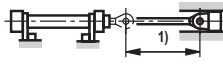
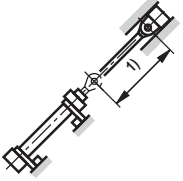
### Type of mounting CDH3/CGH3/CSH3 <sup>2)</sup>: MS2

ØAL	ØMM	admissible stroke length with									Installation position
		100 bar			210 bar			350 bar			
		0°	45°	90°	0°	45°	90°	0°	45°	90°	
40	28	1265	1310	1500	920	935	970	690	695	710	0° 
50	36	1650	1715	2000	1235	1260	1330	950	960	980	
63	45	1995	2000	2000	1520	1550	1655	1180	1190	1220	
80	56	2000	2000	2000	1850	1895	2000	1445	1460	1510	45° 
100	70	2940	3000	3000	2310	2370	2585	1830	1855	1925	
125	90	3000	3000	3000	3000	3000	3000	2640	2685	2810	
140	100	3000	3000	3000	3000	3000	3000	2640	2690	2840	
160	110	3000	3000	3000	3000	3000	3000	2510	2760	2955	
180	125	3000	3000	3000	3000	3000	3000	2900	3000	3000	90° 
200	140	3000	3000	3000	3000	3000	3000	3000	3000	3000	
220	160	6000	6000	6000	5065	5280	6000	4225	4330	4705	
250	180	6000	6000	6000	5590	5835	6000	4455	4805	5250	
280	200	6000	6000	6000	6000	6000	6000	4645	5205	5790	
320	220	6000	6000	6000	6000	6000	6000	4175	4680	6000	1) Adm. stroke length

With longer strokes, an extended guide and/or the use of guide rings may be reasonable for increasing the service life, depending on the respective case of application and installation position. Recommendation on request.

<sup>2)</sup> With CSH3, observe the maximum stroke length "X\*max", pages 24 to 35

## End position cushioning

### End position cushioning:

The objective is to reduce the velocity of a moved mass, the center of gravity of which lies on the cylinder axis, to a level at which neither the cylinder nor the machine into which the cylinder is installed is damaged. For velocities above 20 mm/s, we recommend the use of an end position cushioning feature, which absorbs energy without requiring the use of an additional device. It must, however, always be checked whether end position cushioning is also required for lower velocities with large masses.

### Damping capacity:

When decelerating masses via end position cushioning, the structural-inherent damping capacity must not be exceeded. Cylinders with end position cushioning can achieve their full damping capacity only over the entire stroke length.

With the adjustable end position cushioning version "E", a throttle valve is additionally provided when compared with version "D". End position cushioning version "E" allows cycle times to be optimized. The max. damping capacity can only be achieved when the throttle valve is closed.

The calculation depends on the factors weight, velocity, system pressure and installation position. For this reason, mass and velocity are used to determine the characteristic  $D_m$  and system pressure and installation position to determine the characteristic  $D_p$ .

These two characteristics are used for verifying the admissible damping capacity in the "damping capacity" diagram. The intersection point of the characteristics  $D_m$  and  $D_p$  must always be below the damping capacity curve of the selected cylinder. The values in the diagrams refer to an average oil temperature of +45 to +65 °C with the throttle valve being closed.

For special applications with very short stroke times, high velocities or large masses, cylinders with special end position cushioning versions can be offered on request.

When fixed or adjustable stops are used, special measures must be taken!

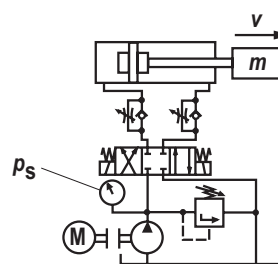

### Formulas:

$$D_m = \frac{m}{10^K}; K = kv(0.5-v)$$

$m$  = Moved weight in kg

$v$  = Stroke velocity in m/s

$kv$  = See table page 60

### Extension for CDH3 and CSH3

$$D_p = p_s - \frac{m \cdot 9.81 \cdot \sin \alpha}{A_1 \cdot 10}$$

### Retraction for CDH3, CGH3 and CSH3; extension for CGH3

$$D_p = p_s + \frac{m \cdot 9.81 \cdot \sin \alpha}{A_3 \cdot 10}$$

$p_s$  = System pressure in bar

$A_1$  = Piston area in cm<sup>2</sup> (see page 4)

$A_3$  = Annulus area in cm<sup>2</sup> (see page 4)

$\alpha$  = Angle to the horizontal in degree

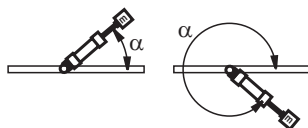

### Damping length

With cylinder strokes within the damping lengths, restrictions with regard to speed / cycle time are possible. We recommend minimum stroke greater than the damping length plus 10 mm!

ØAL mm	40	50	63	80	100	125	140	160	180	200	220	250	280	320
Head side	21	20	23	25	25	25	33	33	37	37	76	81	86	90
Base side	21	20	23	25	25	25	33	33	37	37	76	81	86	90

## End position cushioning

ØAL mm	40	50	63	80	100	125	140	160	180	200	220	250	280	320
$k_v$ ①	1.72	1.85	1.51	1.85	2.34	2.02	1.85	1.93	1.84	1.65	1.41	1.45	1.58	1.68
$k_v$ ②	2.31	1.85	1.95	1.86	2.25	1.97	1.94	1.92	2.05	1.97	1.64	1.61	1.82	1.94

### Damping capacity: Extension for CDH3 and CSH3, with $k_v$ ①

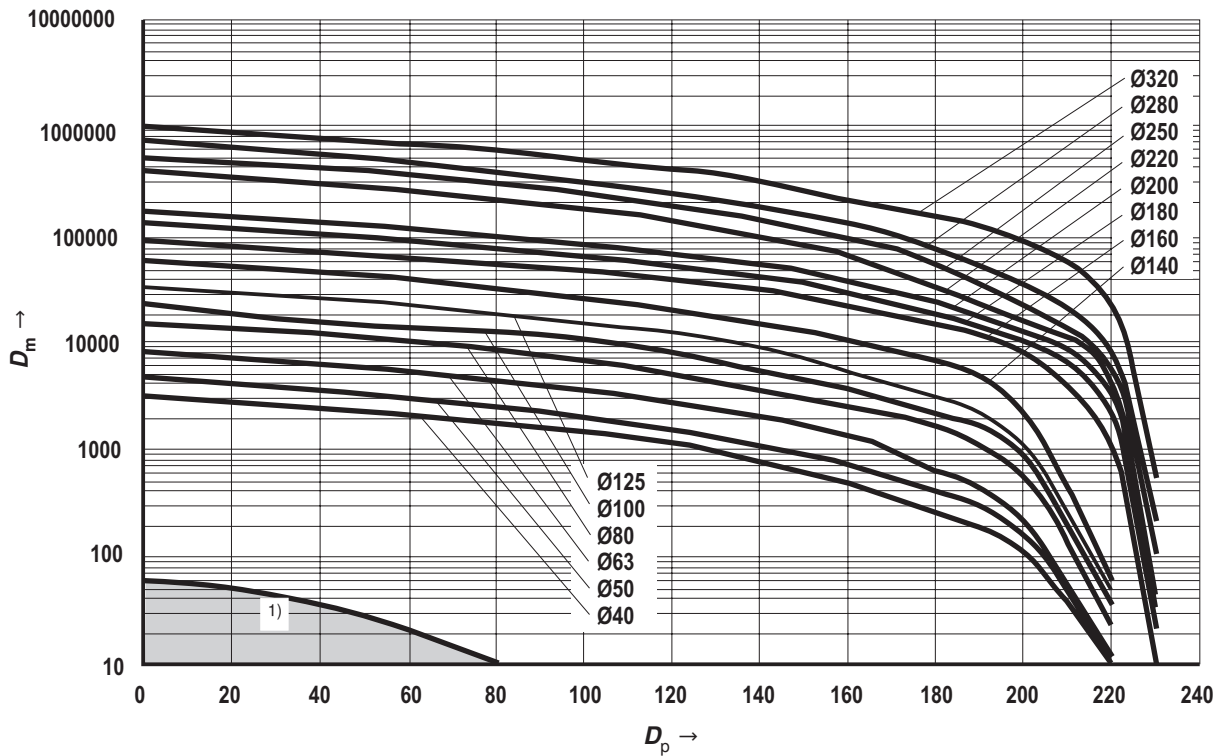

ØAL = Piston Ø

1) If with standard applications the calculated intersection point of  $D_m$  and  $D_p$  is within the marked area, we recommend designing the cylinder without end position cushioning.

## End position cushioning

Damping capacity: Retraction for CDH3, CGH3 and CSH3; extension for CGH3 with  $k_v$  ②

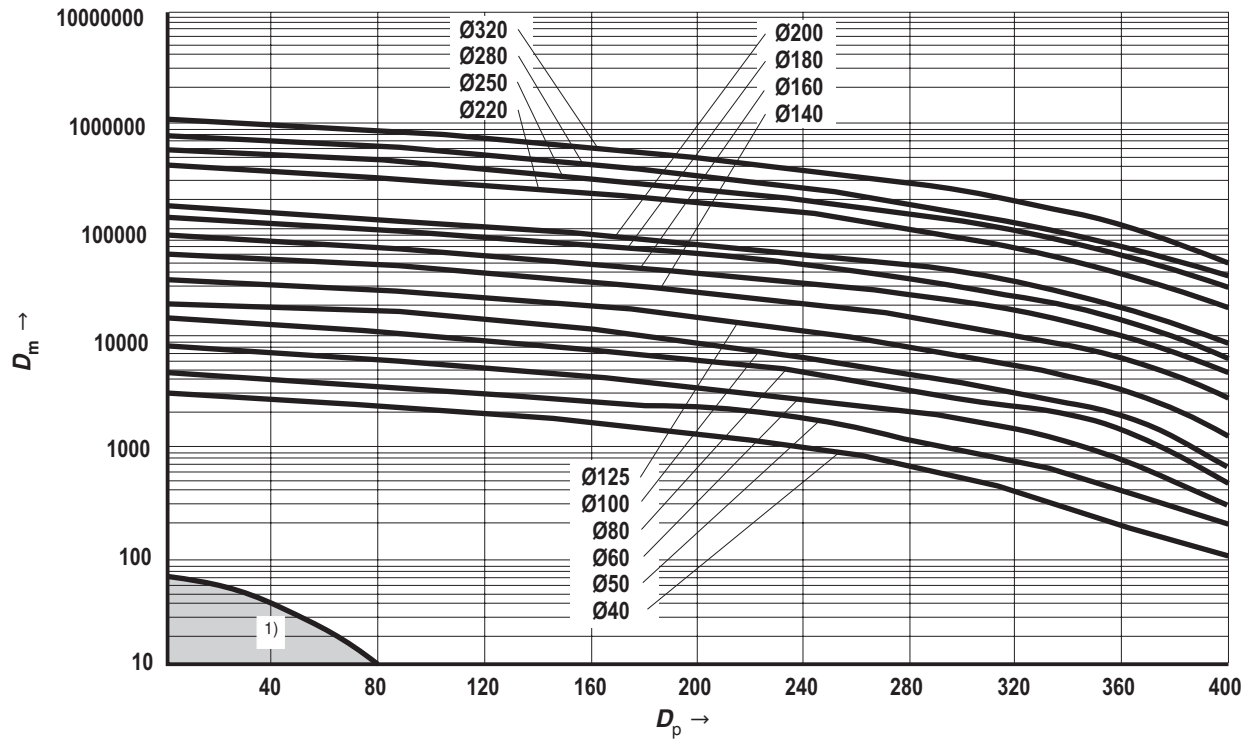

ØAL = Piston Ø

1) If with standard applications the calculated intersection point of  $D_m$  and  $D_p$  is within the marked area, we recommend designing the cylinder without end position cushioning.

## Selection criteria for seals

Work and environmental conditions		Seal versions								
		M	G	V	L	A	B	T	R	S
Medium / temperature	Medium HL, HLP / operating temperature medium -20 °C to +80 °C	++	++	++	++	++	++	++	++	++
	Medium HFA / operating temperature medium +5 °C to +55 °C	+/-	+/-	+/-	+/-	+	+/-	++	+/-	+/-
	Medium HFC / operating temperature medium -20 °C to +60 °C	-	++	-	-	+/-	-	++	-	-
	Medium HFDR / operating temperature medium -15 °C to +80 °C	-	-	++	-	-	++	-	-	++
	Medium HFDU / operating temperature medium -15 °C to +80 °C	-	-	++	-	-	++	-	-	++
	Ambient and rod temperature in the area of the piston rod from -20 °C to +80 °C <sup>1)</sup>	++	+	+ <sup>2)</sup>	++	++	+ <sup>2)</sup>	+	++	++ <sup>2)</sup>
	Extended ambient and rod temperature in the area of the piston rod from +80 °C to +120 °C	-	-	++	-	-	+	-	-	++
Function / velocity...	Static holding function more than 10 minutes: Attention! Application- and temperature-dependent	++	+	+	+	++	++	+	+	+
	Static holding function short-time < 1 minute	++	++	++	++	++	++	++	++	++
	Robust application conditions: Steel works, mining, thin ice	++	++	++	++	++	++	-	++	-
	Zero point control, hardly any amplitude, frequency max. 5 Hz, not longer than 5 minutes	-	-	-	+/-	-	-	++	+	++
	Cylinder velocity min. 0.001 m/sec stick-slip behavior	++	+	+	++	-	-	++	++	++
	Cylinder velocity from 0.01 m/sec to 0.5 m/sec <sup>3)</sup>	++	+	+	++	+	+	++	++	++
	Cylinder velocity > 0.5 m/sec to max. 0.8 m/sec <sup>3)</sup>	-	+/-	+/-	++	-	-	++	+	++
	Stroke > 1.0 m	+/-	++	++	++	++	++	++	++	++
	Standstill period (wear)	++	+/-	+/-	++	+/-	-	++	++	++
Undissolved air in the oil <sup>4)</sup>	-	+	+	+	-	-	+	+	+	

++ = very good

+ = good

+/- = conditional, depending on the application parameters

- = inappropriate

General technical data in corresponding data sheets will remain valid, see page 2!

- 1) Moreover, observe the corresponding medium temperature range
- 2) Lower temperature limit -15 °C
- 3) Standard line connections not designed for that velocity
- 4) - Seal is destroyed / + Seal is not directly destroyed, leakage may occur

Generally, a medium temperature of approx. 40 °C is recommended. The specified values are to be regarded as guidelines; depending on the case of application, it may be necessary to check the suitability of the seal system.

## Seal kits <sup>1)</sup>

### CDH3 – Standard

ØAL	ØMM	Material no. for seal design								
		M	G	V	L	A	B	T	R	S
40	28	R900851087	R961006002	R961006037	R961006072	R900859445	R900859770	R900858841	R961006107	R900861001
50	36	R900849392	R961006005	R961006040	R961006075	R900851515	R900860940	R900860277	R961006110	R900861004
63	45	R900847956	R961006008	R961006043	R961006078	R900851638	R900859678	R900847855	R961006113	R900861007
80	56	R900850905	R961006011	R961006046	R961006081	R900854718	R900851205	R900856180	R961006116	R900861010
100	70	R900853382	R961006014	R961006049	R961006084	R900856094	R900860946	R900860285	R961006119	R900861013
125	90	R900857949	R961006017	R961006052	R961006087	R900856095	R900855464	R900856102	R961006122	R900861016
140	100	R900853965	R961006019	R961006054	R961006089	R900856096	R900860952	R900860290	R961006124	R900849080
160	110	R900851146	R961006021	R961006056	R961006091	R900860933	R900860954	R900857536	R961006126	R900861019
180	125	R900848603	R961006024	R961006059	R961006094	R900860935	R900860956	R900860292	R961006129	R900861021
200	140	R900856431	R961006026	R961006061	R961006096	R900860937	R900860958	R900860293	R961006131	R900861023
220	160	R900888101	R961006028	R961006063	R961006098	R900888117	R900888141	R900888109	R961006133	R900888133
250	180	R900888103	R961006030	R961006065	R961006100	R900888119	R900888143	R900888111	R961006135	R900888135
280	200	R900888105	R961006032	R961006067	R961006102	R900888121	R900888145	R900888113	R961006137	R900888137
320	220	R900888107	R961006034	R961006069	R961006104	R900888123	R900888147	R900888115	R961006139	R900888139

ØAL = Piston Ø

ØMM = Piston rod Ø

<sup>1)</sup> Seal kits for proximity switches and subplate mounting  
separate material no.

Seal kits <sup>1)</sup>

## CGH3 – Standard

ØAL	ØMM	Material no. for seal design								
		M	G	V	L	A	B	T	R	S
40	28	R900867252	R961006223	R961006258	R961006293	R900866747	R900867133	R900868889	R961006328	R900868943
50	36	R900864930	R961006226	R961006261	R961006296	R900866750	R900867136	R900868892	R961006331	R900868946
63	45	R900867262	R961006229	R961006264	R961006299	R900866753	R900867139	R900868895	R961006334	R900868949
80	56	R900867265	R961006232	R961006267	R961006302	R900866756	R900867142	R900868898	R961006337	R900868952
100	70	R900867268	R961006235	R961006270	R961006305	R900866759	R900867146	R900868901	R961006340	R900868955
125	90	R900867270	R961006238	R961006273	R961006308	R900866762	R900867149	R900868904	R961006343	R900868957
140	100	R900867272	R961006240	R961006275	R961006310	R900866764	R900867151	R900868906	R961006345	R900868959
160	110	R900867274	R961006242	R961006277	R961006312	R900866766	R900867153	R900868908	R961006347	R900868961
180	125	R900867276	R961006245	R961006280	R961006315	R900866768	R900867155	R900868910	R961006350	R900868963
200	140	R900867278	R961006247	R961006282	R961006317	R900866770	R900867157	R900868912	R961006352	R900868965
220	160	R900888021	R961006249	R961006284	R961006319	R900888037	R900888061	R900888029	R961006354	R900888053
250	180	R900888023	R961006251	R961006286	R961006321	R900888039	R900888063	R900888031	R961006356	R900888055
280	200	R900888025	R961006253	R961006288	R961006323	R900888041	R900888065	R900888033	R961006358	R900888057
320	220	R900888027	R961006255	R961006290	R961006325	R900888043	R900888067	R900888035	R961006360	R900888059

ØAL = Piston Ø

ØMM = Piston rod Ø

<sup>1)</sup> Seal kits for proximity switches and subplate mounting  
separate material no.



**Seal kits <sup>1)</sup>****CDH3 – Standard + additional option F**

ØAL	ØMM	Material no. for seal design					
		M+F	G+F	V+F	T+F	R+F	S+F
40	28	R900861025	R961006142	R961006169	R900861050	R961006196	R900861100
50	36	R900861028	R961006145	R961006172	R900861053	R961006199	R900861103
63	45	R900861031	R961006148	R961006175	R900861056	R961006202	R900861106
80	56	R900861034	R961006151	R961006178	R900861059	R961006205	R900861109
100	70	R900861037	R961006154	R961006181	R900861062	R961006208	R900861115
125	90	R900861040	R961006157	R961006184	R900861065	R961006211	R900861122
140	100	R900861042	R961006159	R961006186	R900861067	R961006213	R900861126
160	110	R900861044	R961006161	R961006188	R900861069	R961006215	R900861130
180	125	R900861046	R961006164	R961006191	R900861071	R961006218	R900861135
200	140	R900861048	R961006166	R961006193	R900861073	R961006220	R900861143

**CGH3 – Standard + additional option F**

ØAL	ØMM	Material no. for seal design					
		M+F	G+F	V+F	T+F	R+F	S+F
40	28	R900868999	R961006363	R961006390	R900869026	R961006417	R900869093
50	36	R900869002	R961006366	R961006393	R900869029	R961006420	R900869096
63	45	R900869005	R961006369	R961006396	R900869032	R961006423	R900869099
80	56	R900869008	R961006372	R961006399	R900869035	R961006426	R900869102
100	70	R900869013	R961006375	R961006402	R900869038	R961006429	R900869105
125	90	R900869016	R961006378	R961006405	R900869041	R961006432	R900869108
140	100	R900869018	R961006380	R961006407	R900869043	R961006434	R900869110
160	110	R900869020	R961006382	R961006409	R900869045	R961006436	R900869112
180	125	R900869022	R961006385	R961006412	R900869047	R961006439	R900869114
200	140	R900869024	R961006387	R961006414	R900869049	R961006441	R900869116

ØAL = Piston Ø

ØMM = Piston rod Ø

<sup>1)</sup> Seal kits for proximity switches and subplate mounting  
separate material no.

Seal kits <sup>2)</sup>

## CSH3

ØAL	ØMM	Material no. for seal design						
		M	G	V	L	T	R	S
40	28	R900861025	R961006142	R961006169	R961006072	R900861050	R961006196	R900861100
50	36	R900861028	R961006145	R961006172	R961006075	R900861053	R961006199	R900861103
63	45	R900861031	R961006148	R961006175	R961006078	R900861056	R961006202	R900861106
80	56	R900861034	R961006151	R961006178	R961006081	R900861059	R961006205	R900861109
100	70	R900861037	R961006154	R961006181	R961006084	R900861062	R961006208	R900861115
125	90	R900861040	R961006157	R961006184	R961006087	R900861065	R961006211	R900861122
140	100	R900861042	R961006159	R961006186	R961006089	R900861067	R961006213	R900861126
160	110	R900861044	R961006161	R961006188	R961006091	R900861069	R961006215	R900861130
180	125	R900861046	R961006164	R961006191	R961006094	R900861071	R961006218	R900861135
200	140	R900861048	R961006166	R961006193	R961006096	R900861073	R961006220	R900861143
220	160	R900888101	R961006028	R961006063	R961006098	R900888109	R961006133	R900888133
250	180	R900888103	R961006030	R961006065	R961006100	R900888111	R961006135	R900888135
280	200	R900888105	R961006032	R961006067	R961006102	R900888113	R961006137	R900888137
320	220	R900888107	R961006034	R961006069	R961006104	R900888115	R961006139	R900888139

ØAL = Piston Ø

ØMM = Piston rod Ø

<sup>2)</sup> Seal kits for position measurement system and subplate mounting separate material no.

## Seal kits

### Only for proximity switches

ØAL	Material no. for seal design								
	M / M+F	T / T+F	G / G+F	L	R / R+F	A	S / S+F	V / V+F	B
40 to 200	R900885938						R900885939		
220 to 320	R900894997						R900894998		

### Only for subplate mounting

ØAL	Material no. for seal design	
	M, T, G, L, R, A	S, B, V
40	R961006022	R961006243
50	R961006022	R961006243
63	R961006092	R961006313
80	R961006092	R961006313
100	R961006092	R961006313
125	R961006162	R961006383
140	R961006162	R961006383
160	R961006189	R961006410
180	R961006189	R961006410
200	R961006189	R961006410

### Only for position measurement system

ØAL	Material no. for seal design	
	M, T, G, L, R	S, V
40	R900885935	R900885937
50	R900894958	R900894979
63	R900894959	R900894980
80	R900894960	R900894981
100	R900894961	R900894982
125	R900894962	R900894983
140	R900894963	R900894985
160	R900894964	R900894986
180	R900894973	R900894987
200	R900894974	R900894988
220	R900894975	R900894989
250	R900894976	R900894991
280	R900894977	R900894993
320	R900894978	R900894994

ØAL = Piston Ø

## Tightening torques

Screws: Head and base (item 1 and 2)

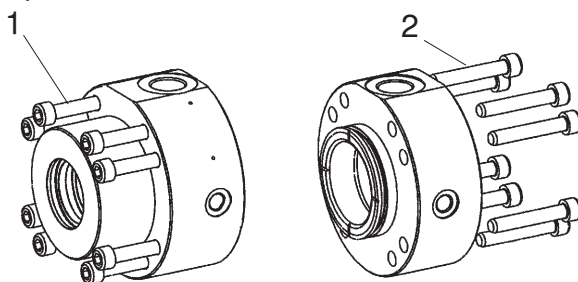

Series	Piston Ø	Screw	Quantity	Quality class	Tightening torque
CDH3 / CGH3 / CSH3	40	M10	4	10.9	40 Nm
CDH3 / CGH3 / CSH3	50	M8	8	10.9	25 Nm
CDH3 / CGH3 / CSH3	63	M10	8	10.9	50 Nm
CDH3 / CGH3 / CSH3	80	M12	8	10.9	90 Nm
CDH3 / CGH3 / CSH3	100	M16	8	10.9	175 Nm
CDH3 / CGH3 / CSH3	125	M20	8	10.9	350 Nm
CDH3 / CGH3 / CSH3	140	M20	8	10.9	450 Nm
CDH3 / CGH3 / CSH3	160	M24	8	10.9	670 Nm
CDH3 / CGH3 / CSH3	180	M24	12	10.9	580 Nm
CDH3 / CGH3 / CSH3	200	M24	12	10.9	720 Nm
CDH3 / CGH3 / CSH3	220	M24	16	10.9	750 Nm
CDH3 / CGH3 / CSH3	250	M30	16	10.9	1400 Nm
CDH3 / CGH3 / CSH3	280	M30	16	10.9	1600 Nm
CDH3 / CGH3 / CSH3	320	M42	12	10.9	4200 Nm

Screws: Seal cover (item 3)

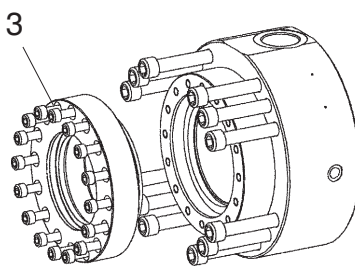

Only with seal design "A" and "B"

Series	Piston Ø	Piston rod Ø	Screw	Quantity	Quality class	Tightening torque
CDH3 / CGH3	160	110	M10	16	10.9	60 Nm
CDH3 / CGH3	180	125	M12	16	10.9	80 Nm
CDH3 / CGH3	200	140	M12	16	10.9	90 Nm
CDH3 / CGH3	220	160	M12	24	10.9	90 Nm
CDH3 / CGH3	250	180	M16	16	10.9	90 Nm
CDH3 / CGH3	280	200	M16	16	10.9	230 Nm
CDH3 / CGH3	320	220	M16	24	10.9	230 Nm

### Spare parts: Series CDH3

CDH3

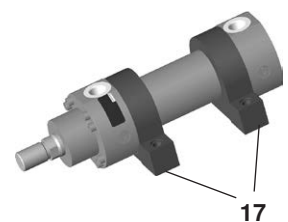
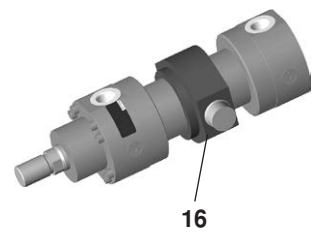
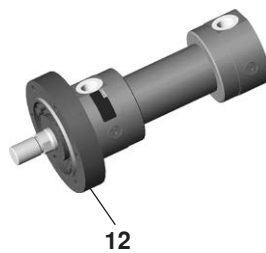
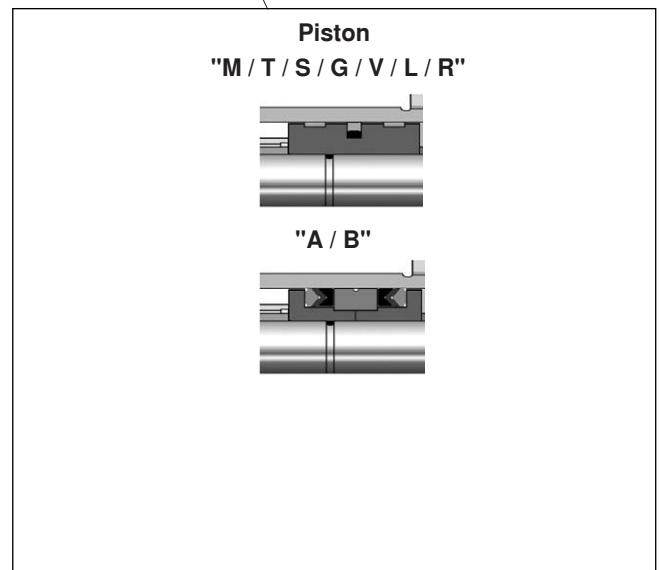
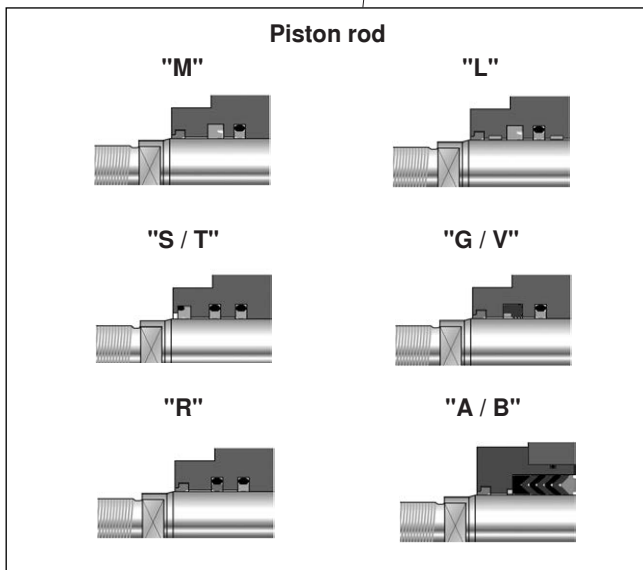
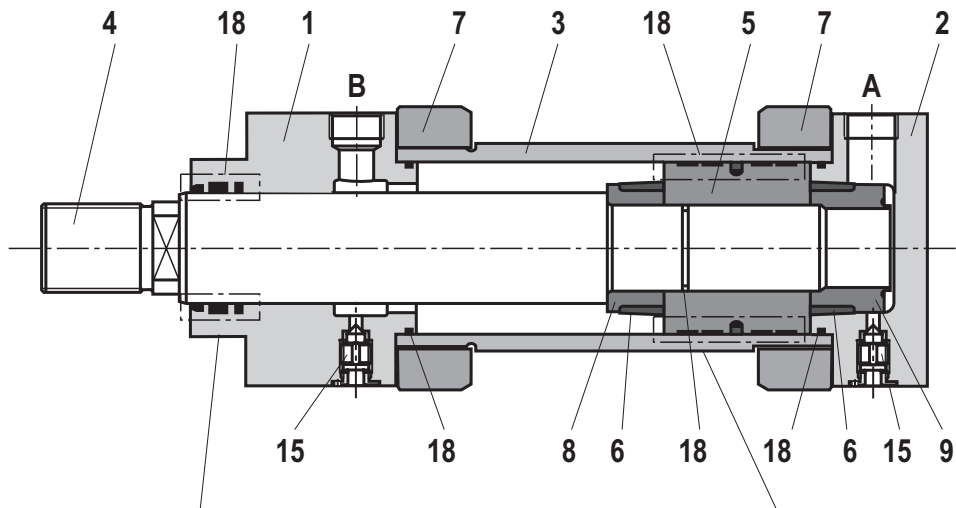

- A** Piston chamber
- B** Annulus area
- 1** Head
- 2** Base
- 3** Pipe
- 4** Piston rod

- 5** Piston
- 6** Damping bush
- 7** Flange
- 8** Socket
- 9** Socket
- 10** Base MP3

- 11** Base MP5
- 12** Round flange MF3
- 14** Round flange MF4
- 15** Bleeding
- 16** Trunnion MT4

- 17** Foot MS2
- 18** Seal kit:
  - Wiper
  - Rod seal
  - Piston seal
  - O-ring
  - Guide ring

### Spare parts: Series CGH3

CGH3

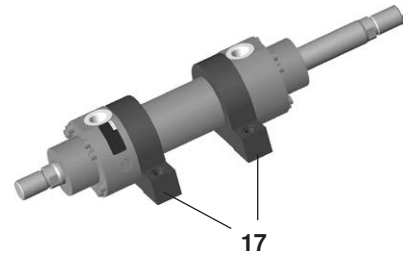
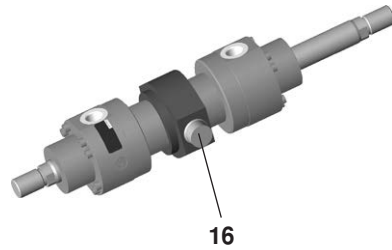
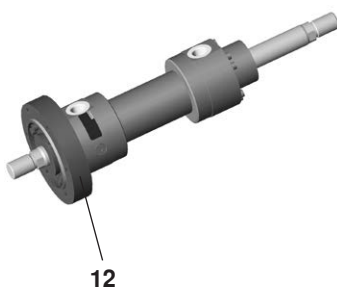
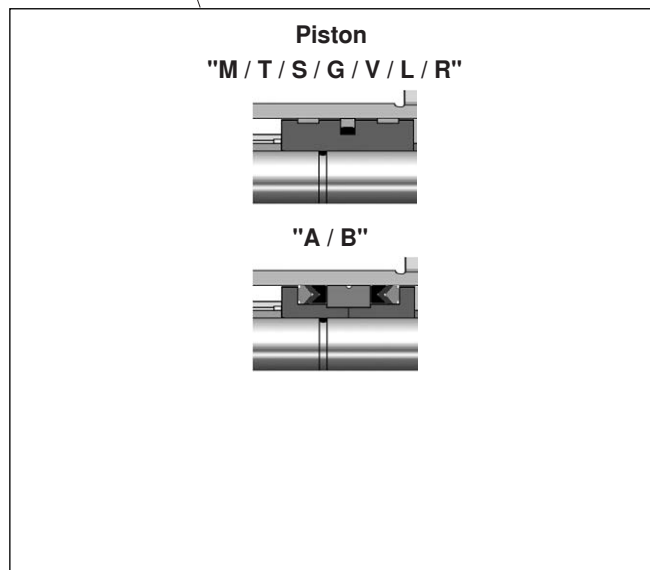
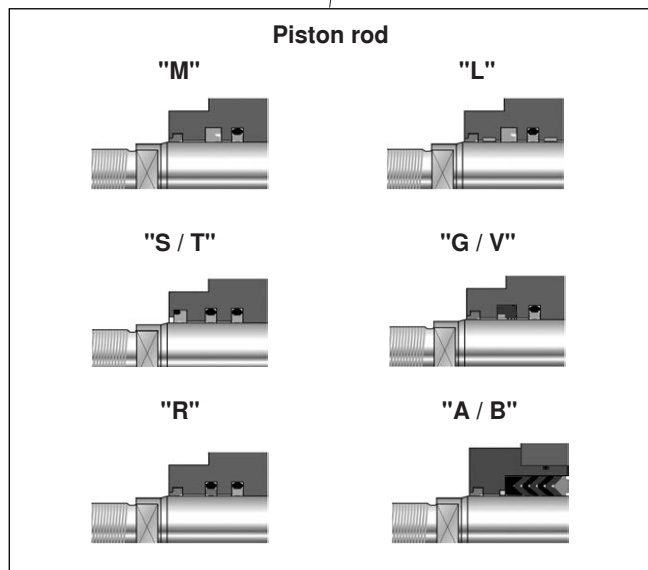
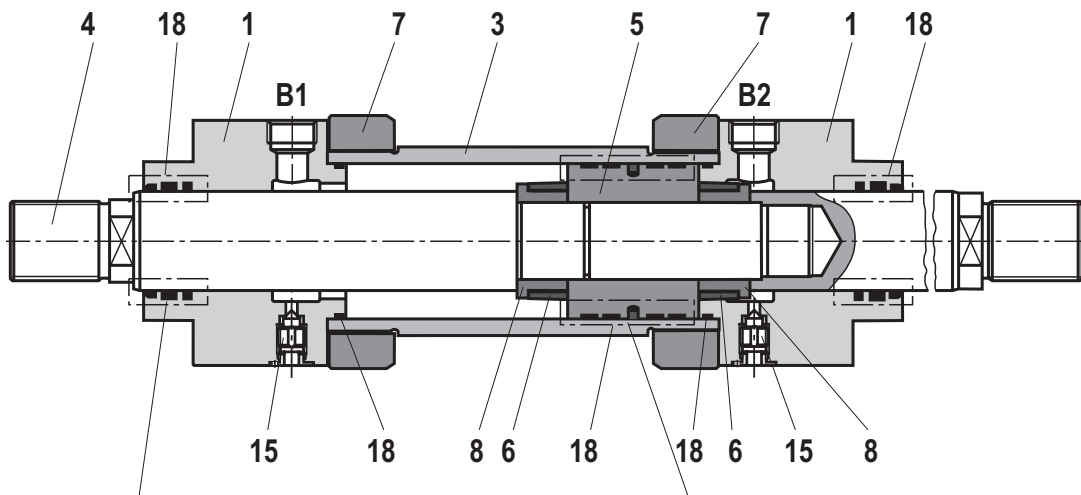

- B1** Annulus area 1
- B2** Annulus area 2
- 1** Head
- 3** Pipe
- 4** Piston rod
- 5** Piston
- 6** Damping bush
- 7** Flange
- 8** Socket

- 12** Round flange MF3
- 15** Bleeding
- 16** Trunnion MT4
- 17** Foot MS2
- 18** Seal kit:
  - Wiper
  - Rod seal
  - Piston seal
  - O-ring
  - Guide ring

Spare parts: Series CSH3 MP3 and MP5

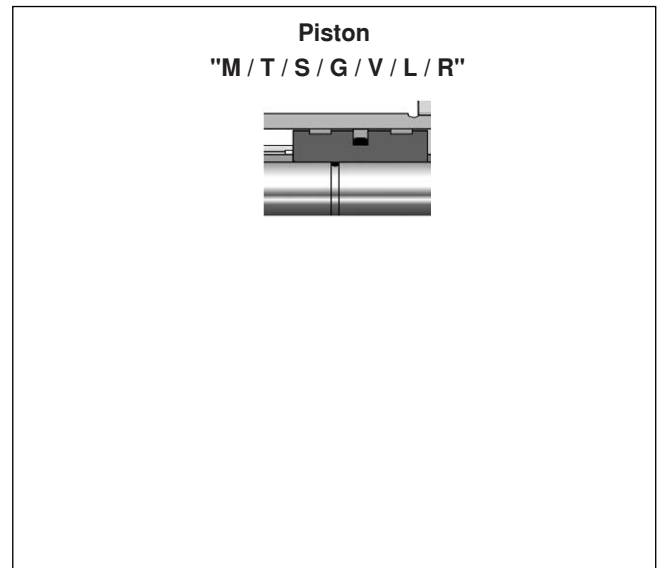
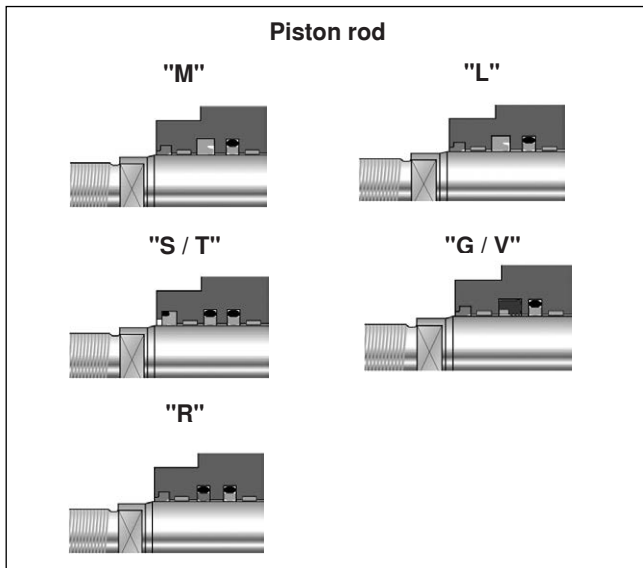
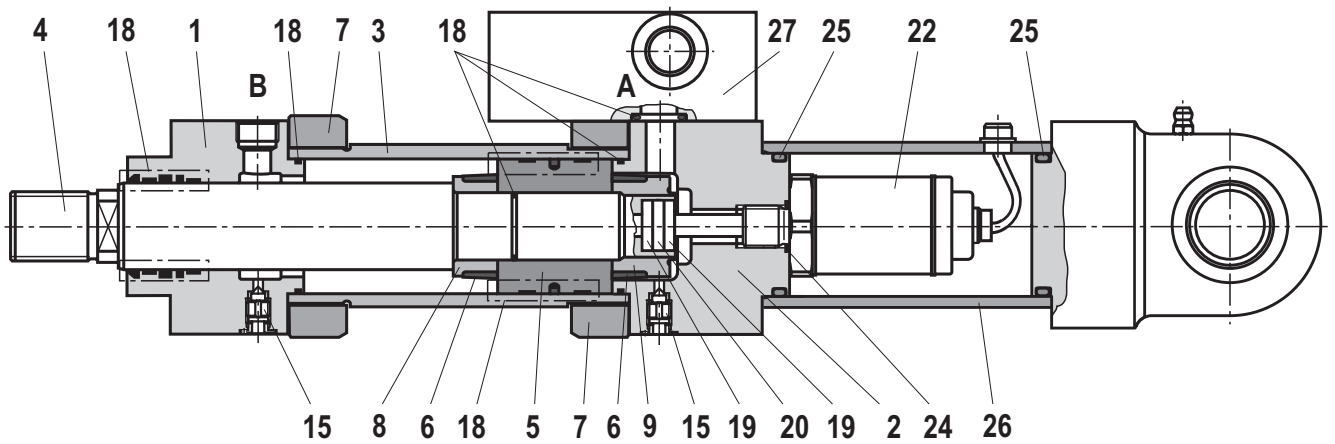

- |                         |                       |                     |                               |
|-------------------------|-----------------------|---------------------|-------------------------------|
| <b>A</b> Piston chamber | <b>5</b> Piston       | <b>11</b> Base MP 5 | <b>19</b> Insulating socket   |
| <b>B</b> Annulus area   | <b>6</b> Damping bush | <b>15</b> Bleeding  | <b>20</b> Solenoid            |
| <b>1</b> Head           | <b>7</b> Flange       | <b>18</b> Seal kit: | <b>22</b> Position transducer |
| <b>2</b> Base           | <b>8</b> Socket       | Wiper               | <b>24</b> Seal                |
| <b>3</b> Pipe           | <b>9</b> Socket       | Rod seal            | <b>25</b> Seal                |
| <b>4</b> Piston rod     | <b>10</b> Base MP3    | Piston seal         | <b>26</b> Protective pipe     |
|                         |                       | O-ring              | <b>27</b> Subplate            |
|                         |                       | Guide ring          |                               |

## Spare parts: Series CSH3 MF3, MF4, MT4 and MS2

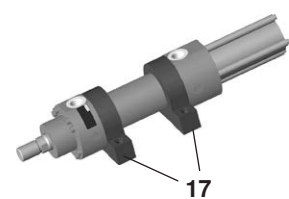
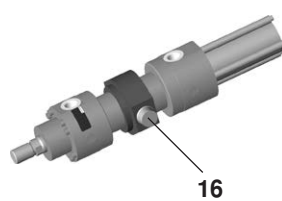
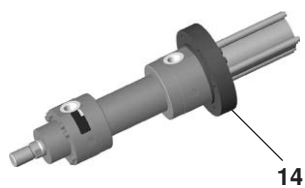
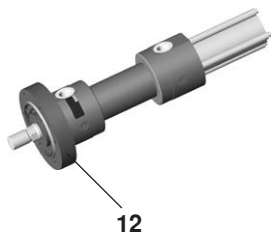
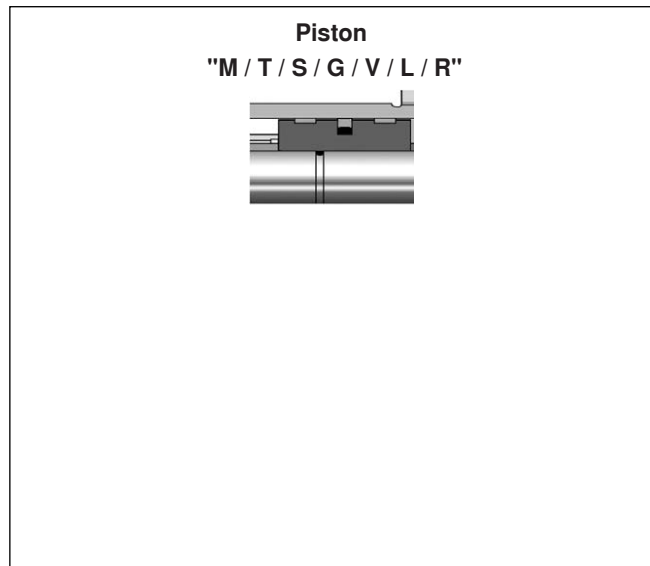
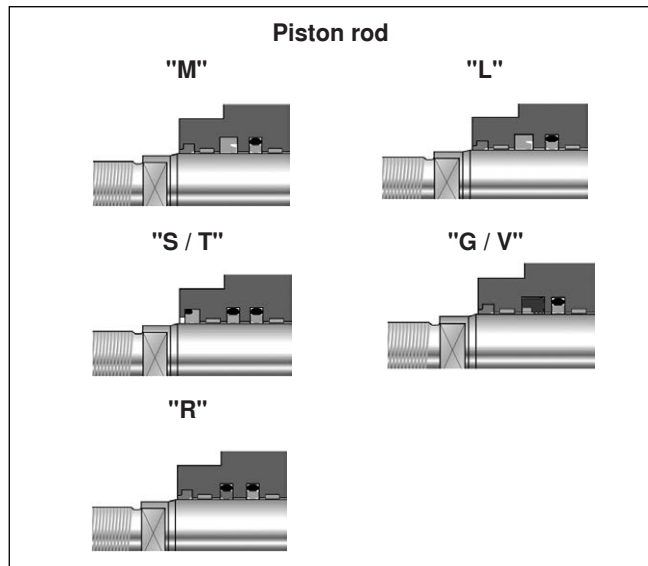
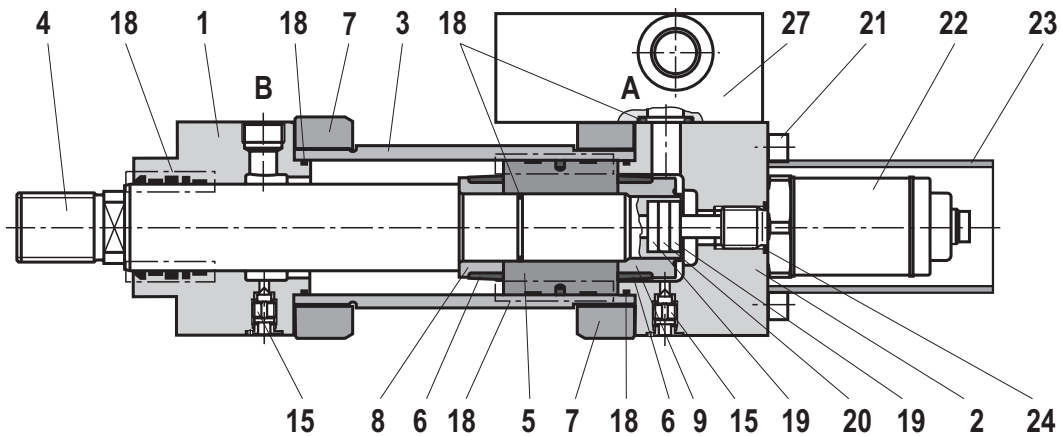

- |                         |                            |                        |  |
|-------------------------|----------------------------|------------------------|--|
| <b>A</b> Piston chamber | <b>6</b> Damping bush      | <b>16</b> Trunnion MT4 | <b>19</b> Insulating socket              |
| <b>B</b> Annulus area   | <b>7</b> Flange            | <b>17</b> Foot MS2     | <b>20</b> Solenoid                       |
| <b>1</b> Head           | <b>8</b> Socket            | <b>18</b> Seal kit:    | <b>21</b> Hexagon socket head cap screws |
| <b>2</b> Base           | <b>9</b> Socket            | Wiper                  | <b>22</b> Position transducer            |
| <b>3</b> Pipe           | <b>12</b> Round flange MF3 | Rod seal               | <b>23</b> Protective pipe                |
| <b>4</b> Piston rod     | <b>14</b> Round flange MF4 | Piston seal            | <b>24</b> Seal                           |
| <b>5</b> Piston         | <b>15</b> Bleeding         | O-ring                 | <b>27</b> Subplate                       |
|                         |                            | Guide ring             |  |



## Cylinder weight

Piston	Piston rod	CD/CS cylinder with 0 mm stroke length					per 100 mm stroke length	CG cylinder with 0 mm stroke length			per 100 mm stroke length
<b>ØAL</b>	<b>ØMM</b>	<b>MP3</b> <sup>1)</sup> <b>MP5</b> <sup>1)</sup>	<b>MP3</b> <sup>2)</sup> <b>MP5</b> <sup>2)</sup>	<b>MF3</b> <b>MF4</b>	<b>MT4</b>	<b>MS2</b>		<b>MF3</b>	<b>MT4</b>	<b>MS2</b>	
mm	mm	kg	kg	kg	kg	kg	kg	kg	kg	kg	kg
<b>40</b>	<b>28</b>	8	14	11	11	9	1.2	12	12	10	1.6
<b>50</b>	<b>36</b>	12	20	17	15	15	1.6	19	17	17	2.4
<b>63</b>	<b>45</b>	26	41	32	30	32	2.6	37	35	36	3.8
<b>80</b>	<b>56</b>	33	44.5	43	40	42	4.2	49	46	48	6.1
<b>100</b>	<b>70</b>	58	74.5	72	71	73	5.7	80	79	81	8.8
<b>125</b>	<b>90</b>	120	150	148	145	149	11.1	170	166	171	16.1
<b>140</b>	<b>100</b>	167	203	205	202	206	13.0	236	233	236	19.1
<b>160</b>	<b>110</b>	229	284	276	276	275	16.3	316	316	315	23.8
<b>180</b>	<b>125</b>	317	383	387	386	404	19.5	456	455	473	29.1
<b>200</b>	<b>140</b>	425	500	506	504	531	24.4	562	560	587	36.5
<b>220</b>	<b>160</b>	514	623	653	570	590	37.8	753	671	690	53.6
<b>250</b>	<b>180</b>	777	959	939	854	829	46.2	1057	972	948	66.2
<b>280</b>	<b>200</b>	915	1147	1073	1028	984	59.7	1224	1179	1135	84.3
<b>320</b>	<b>220</b>	1200	1479	1274	1211	1211	68.3	1431	1369	1369	98.1

ØAL = Piston Ø

ØMM = Piston rod Ø

<sup>1)</sup> Weight without position measurement system

<sup>2)</sup> Weight with position measurement system

## Corrosivity categories

In this connection, observe the information on the color set-up on page 2 "Technical data".

The specified resistances of the individual Bosch Rexroth classes only refer to the primed / painted cylinder areas, not, for example, to piston rods, trunnions, etc.

In this connection, special measures may be necessary.

	Class	Properties	Applications	
			Inside	Outside
<b>Priming</b>	CP3 (C3, short <sup>1)</sup> )	240 h salt spray test SST (DIN EN ISO 9227) 240 h condensation water test KKT (DIN EN ISO 6270-2) Layer thickness: min. 40 µm	Field of application e. g. hall atmosphere, air humidity ≤ 60%, no thermal load.	Not suitable for outdoor exposure.
<b>Painting</b>	CP4 (C3, medium <sup>1)</sup> )	480 h salt spray test SST. (DIN EN ISO 9227) 480 h condensation water test KKT (DIN EN ISO 6270-2) Nominal layer thickness: 120 µm	Unheated buildings in which there may be condensation (production rooms, storage and sport halls).	
	CP5 (C4, medium <sup>1)</sup> )	720 h salt spray test SST (DIN EN ISO 9227) 480 h condensation water test KKT (DIN EN ISO 6270-2) Nominal layer thickness: 140 µm	Silo and debris facilities, chemical plants, boathouses above sea water, laundries, breweries with high humidity and medium contamination.	Industrial and coastal areas with medium salt load.
	CP6 (C5I, medium <sup>1)</sup> )	1000 h salt spray test NSS (DIN EN ISO 9227) 480 h condensation water test KKT (DIN EN ISO 6270-2) Nominal layer thickness: 220 µm	Buildings or areas with almost permanent condensation and serious contamination.	Industrial areas with large humidity and aggressive atmosphere.
	CP7 (C5M, medium <sup>1)</sup> )	1440 h salt spray test NSS (DIN EN ISO 9227) 720 h condensation water test KKT (DIN EN ISO 6270-2) Nominal layer thickness: 320 µm	Buildings or areas with almost permanent condensation and with serious contamination.	Coastal and offshore areas with high salt load.

<sup>1)</sup> according to DIN EN ISO 12944-2

## Notes

---

Bosch Rexroth AG  
Industrial Hydraulics  
Zum Eisengießer 1  
97816 Lohr am Main, Germany  
Phone +49 (0) 93 52/40 30 20  
my.support@boschrexroth.de  
www.boschrexroth.de

© This document, as well as the data, specifications and other information set forth in it, are the exclusive property of Bosch Rexroth AG. It may not be reproduced or given to third parties without its consent. The data specified above only serve to describe the product. No statements concerning a certain condition or suitability for a certain application can be derived from our information. The information given does not release the user from the obligation of own judgment and verification. It must be remembered that our products are subject to a natural process of wear and aging.

## Notes

---

